

# LEGO Mindstorms EV3 BASK3TBALL

## Robot Build Instructions

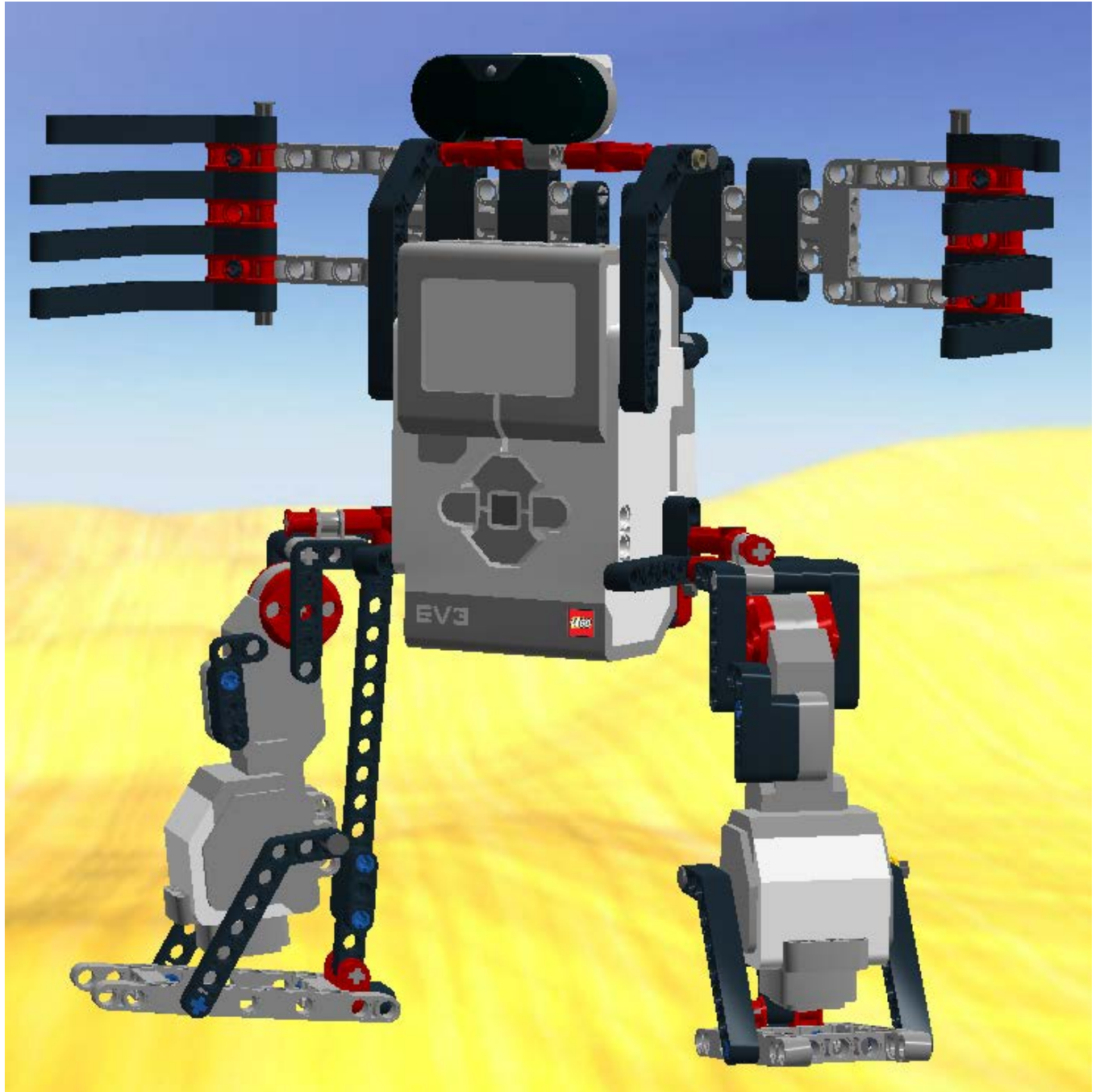

# Body

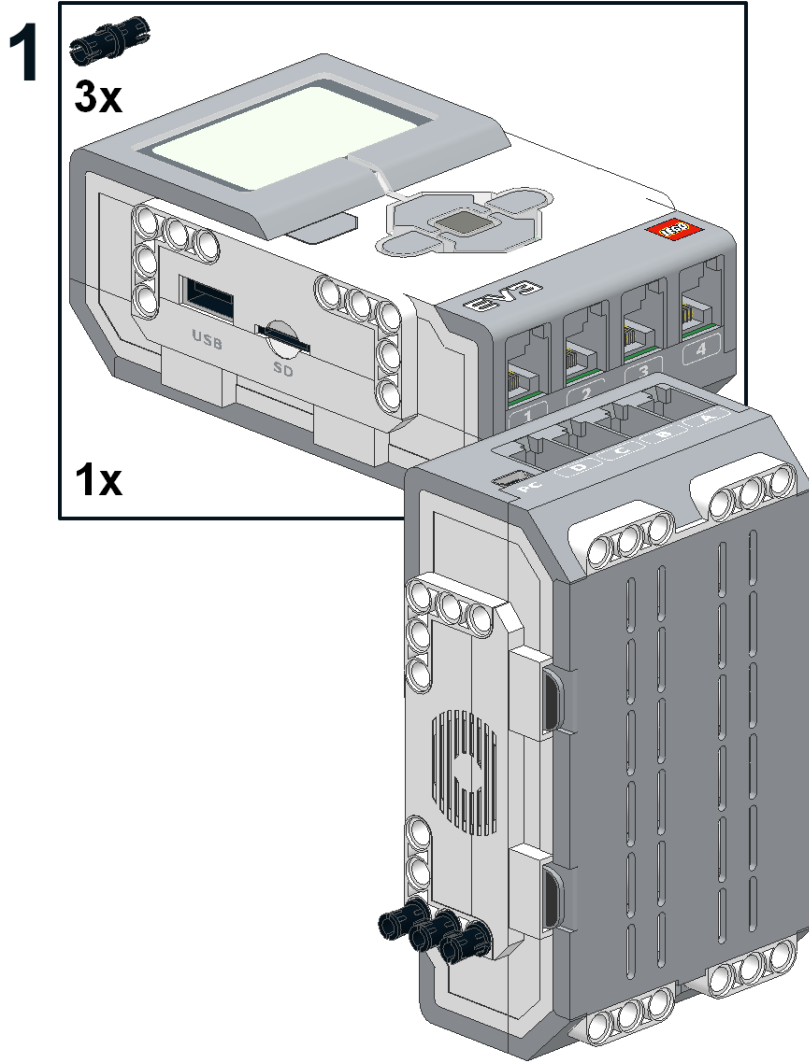

2

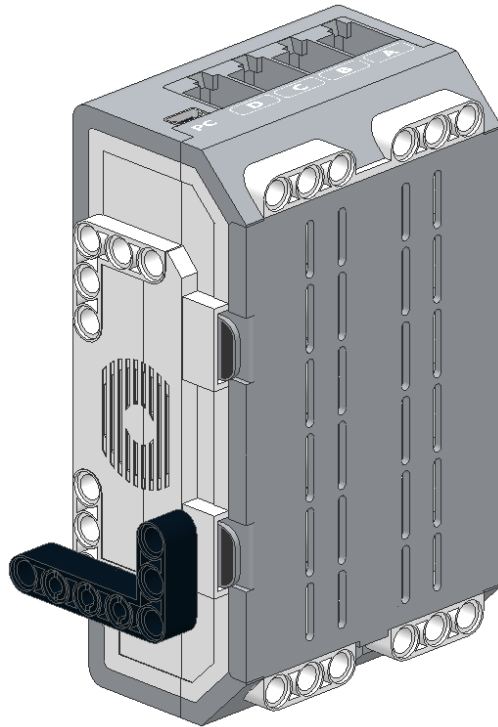
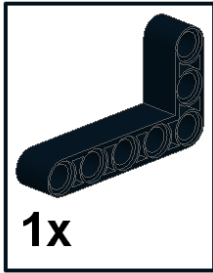

**3**   
**3x**

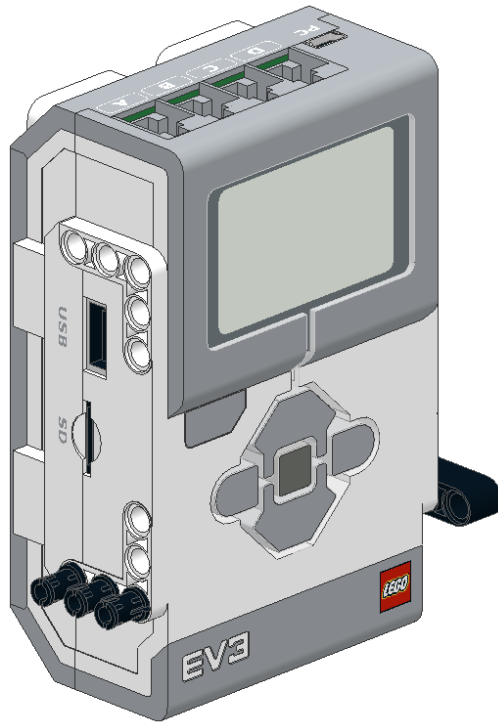

4

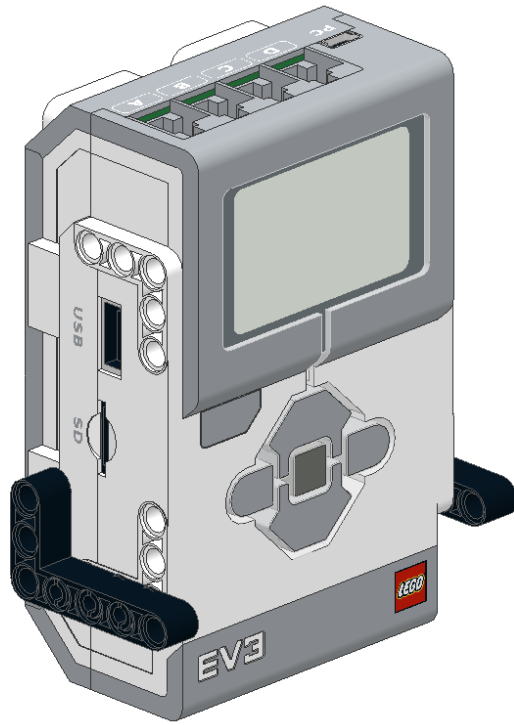
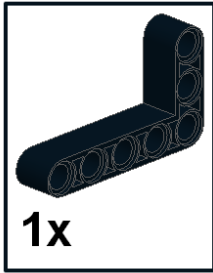

5   
2x

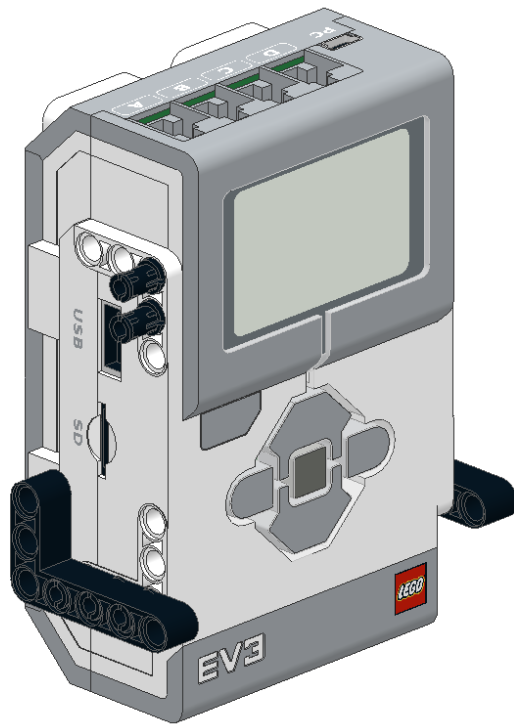

6

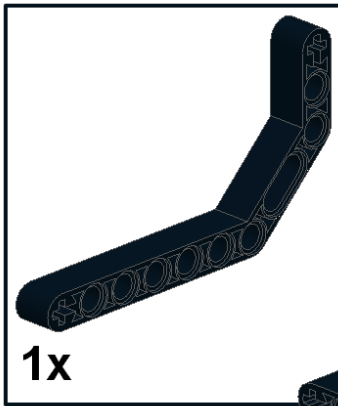

7   
2x

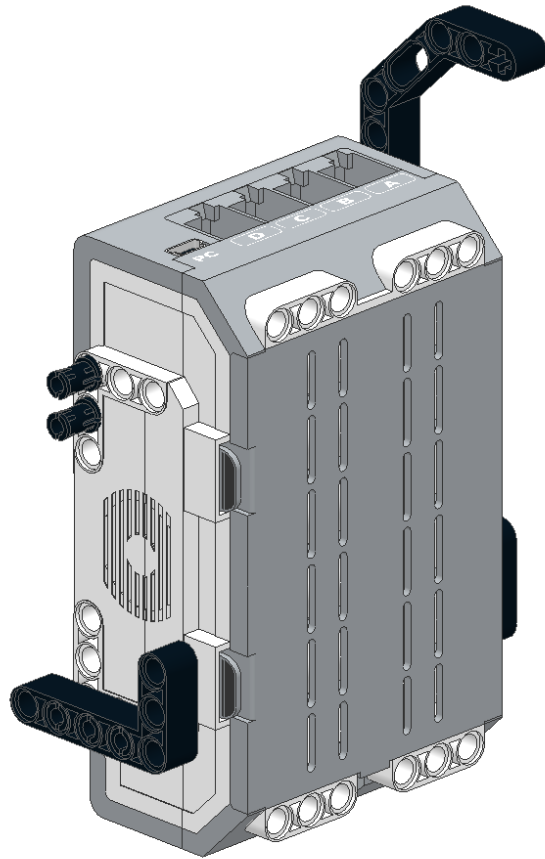



8

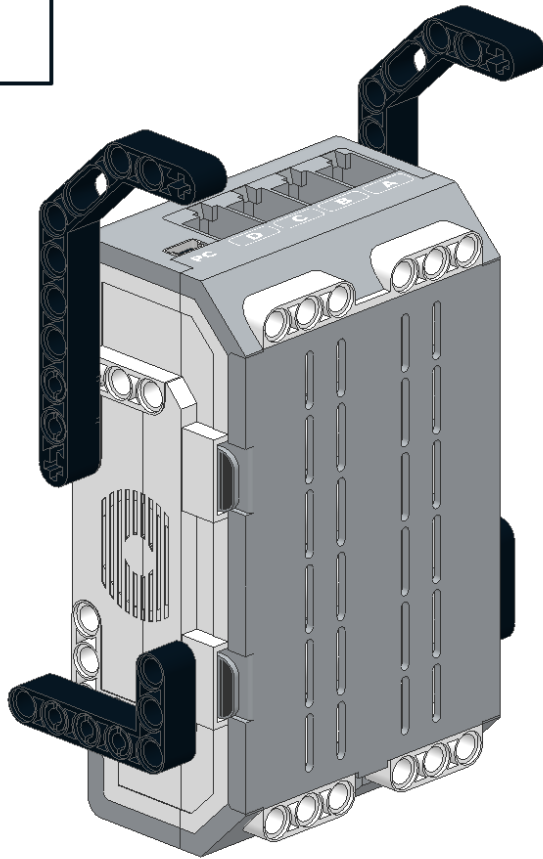
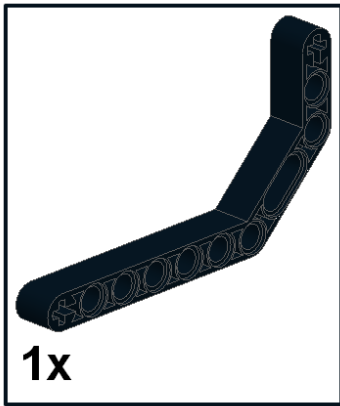

9   
6x

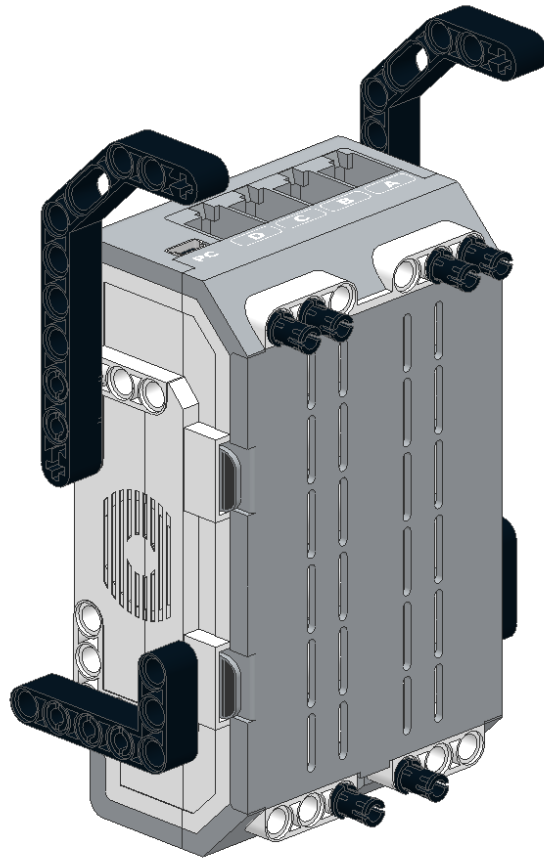

10

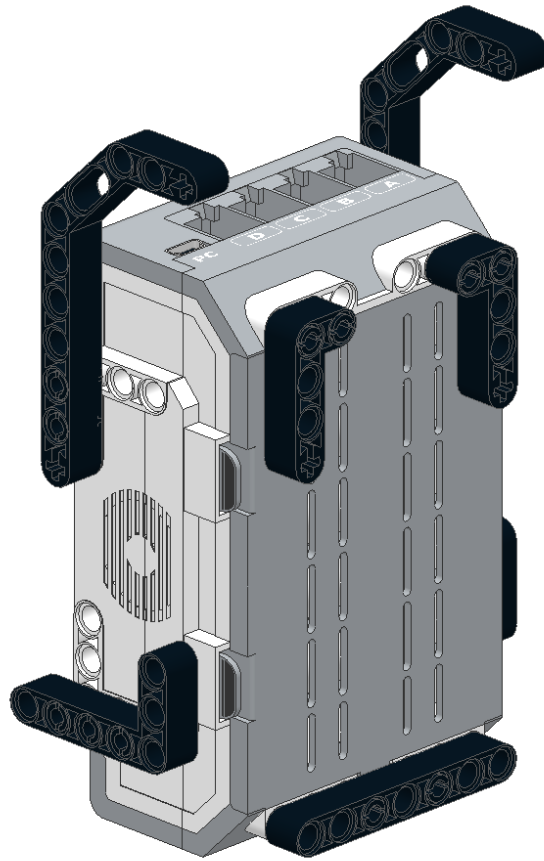
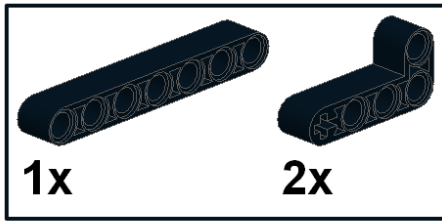

11

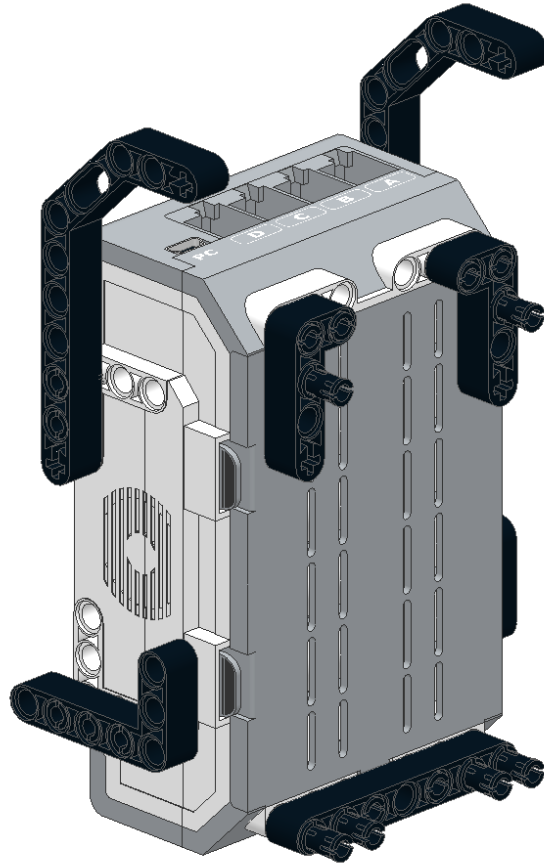

12

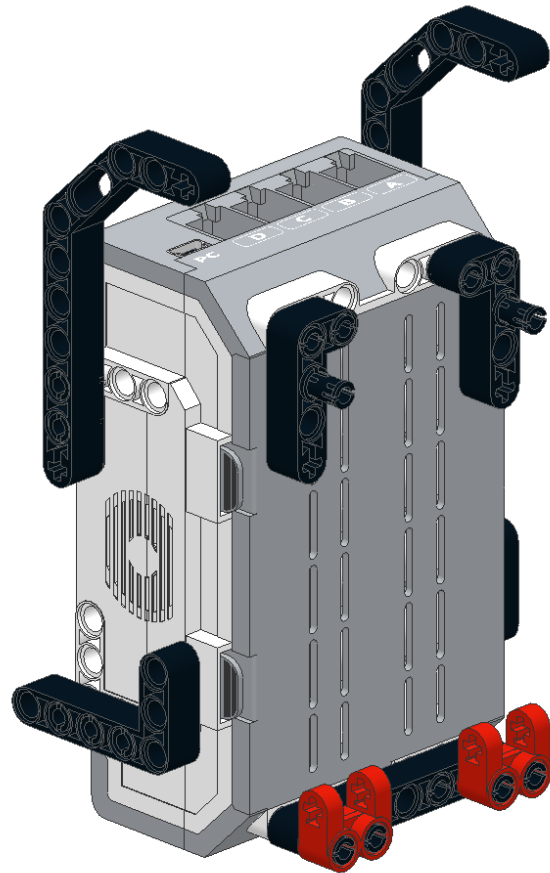

13

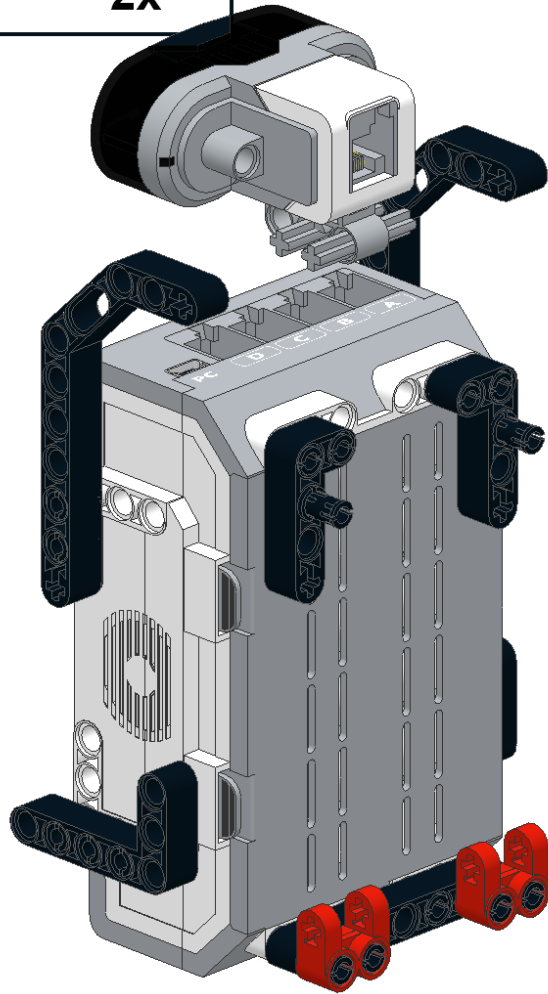
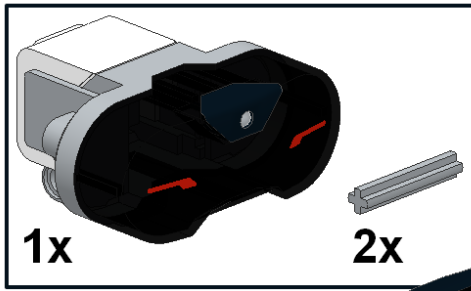

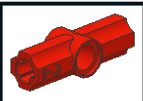
14   
2x

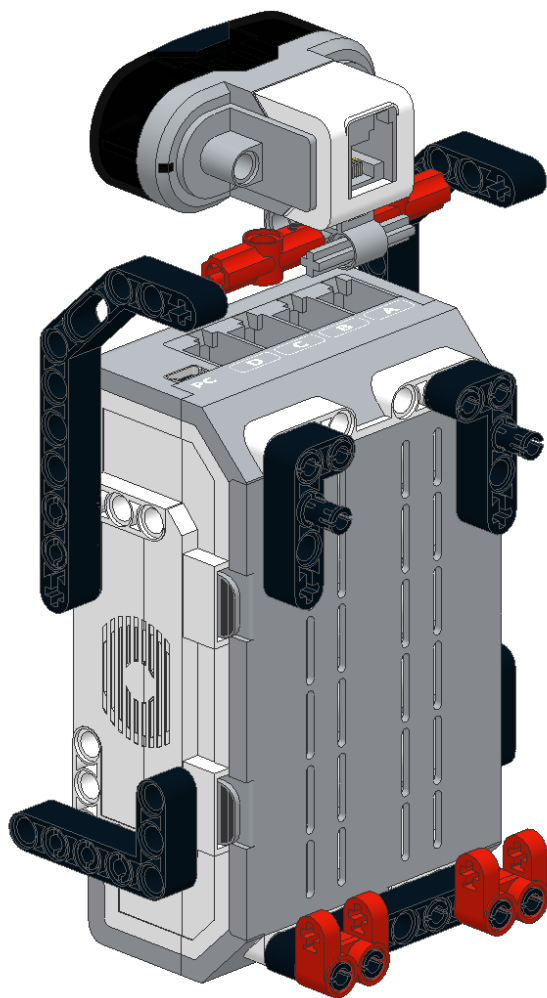

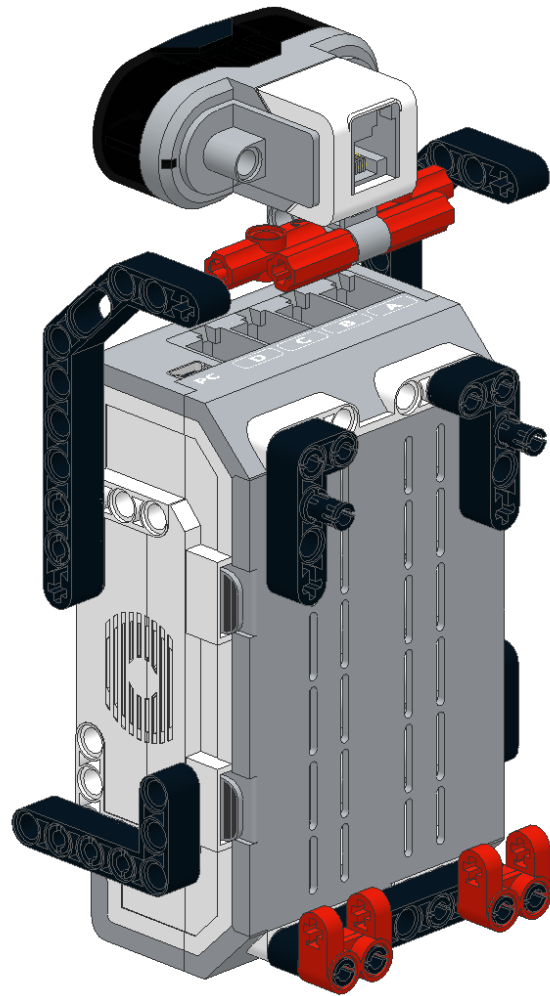

15  2x





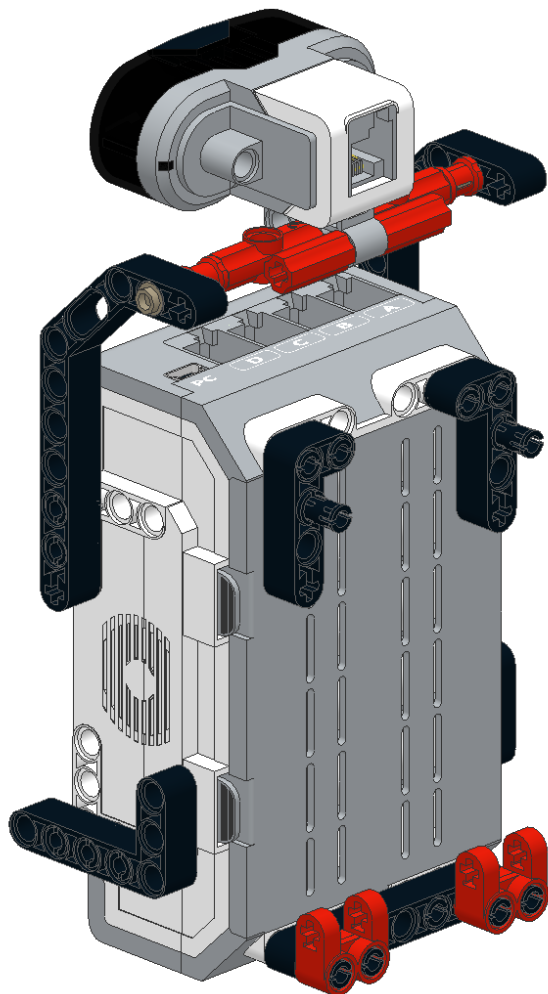

16

	
2x	2x

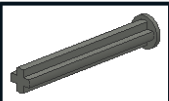

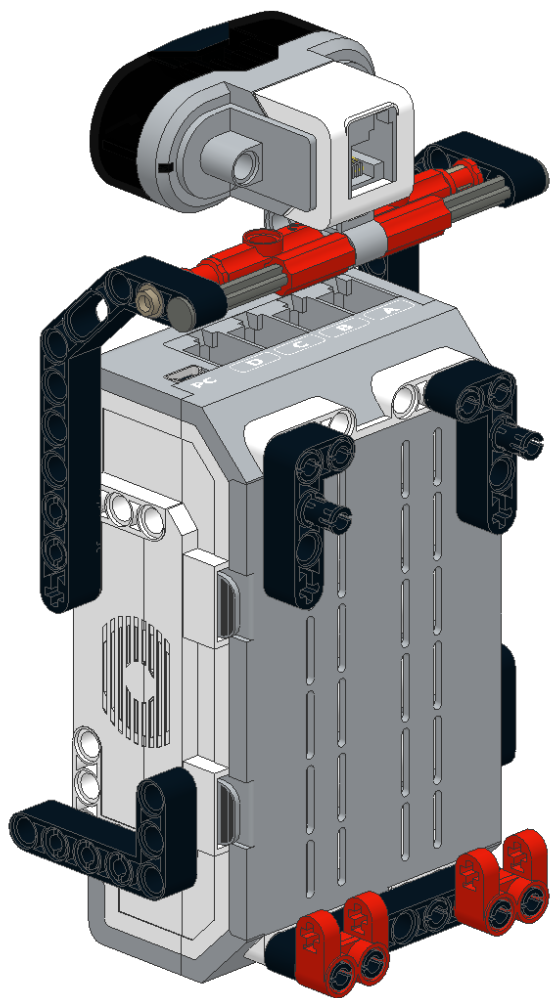
17   
2x



18   
2x



19

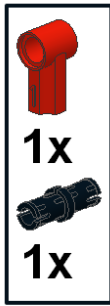

20

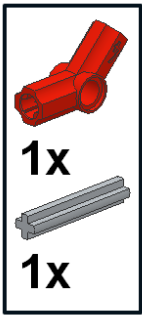

21   
2x

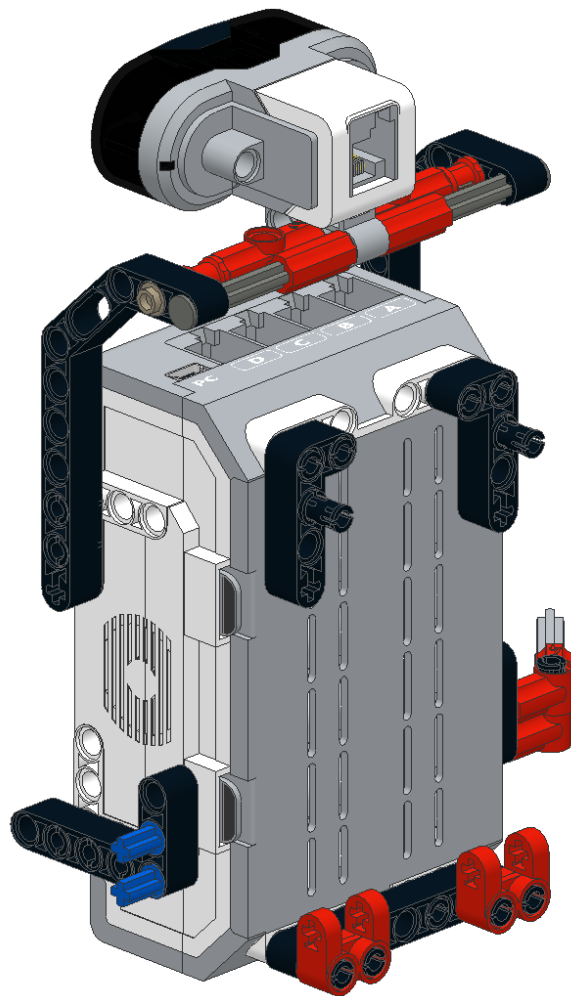

22



1x



1x

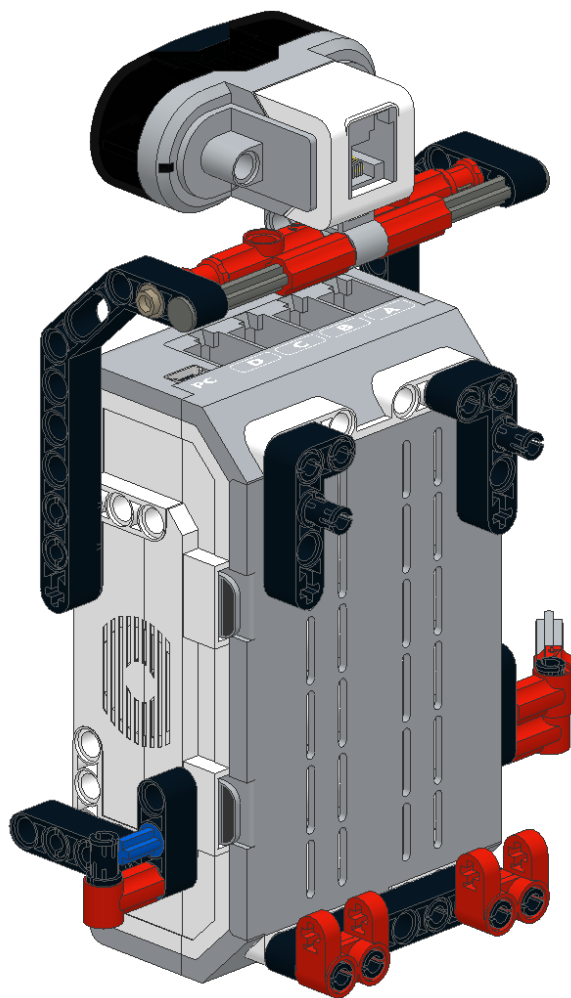

23

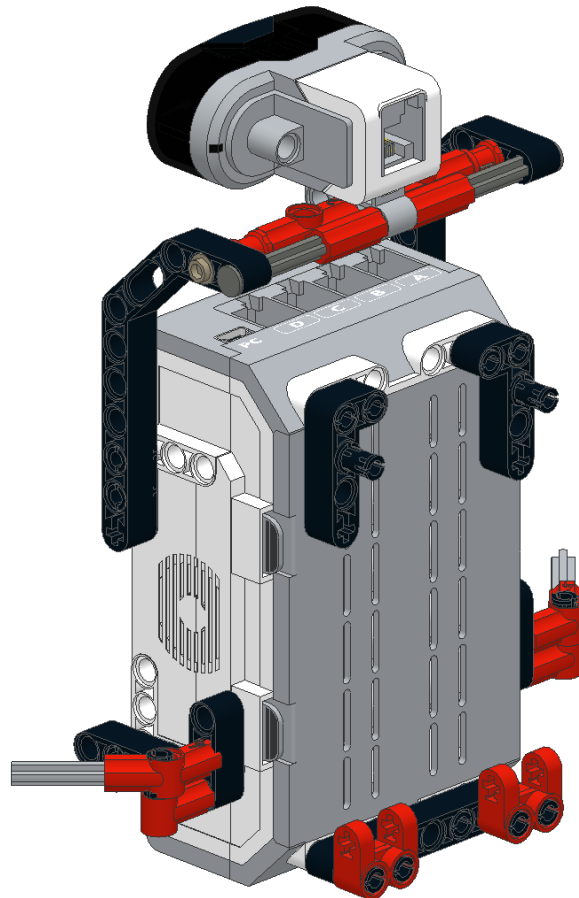
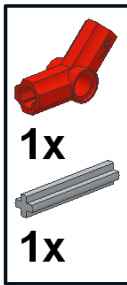

23

**Before Next Step:** Route 4 wires (1 x 25cm, 1 x 35cm, 2 x 50cm) along the back side of the EV3 brick. The next 2 pieces will secure the wires in place.



24

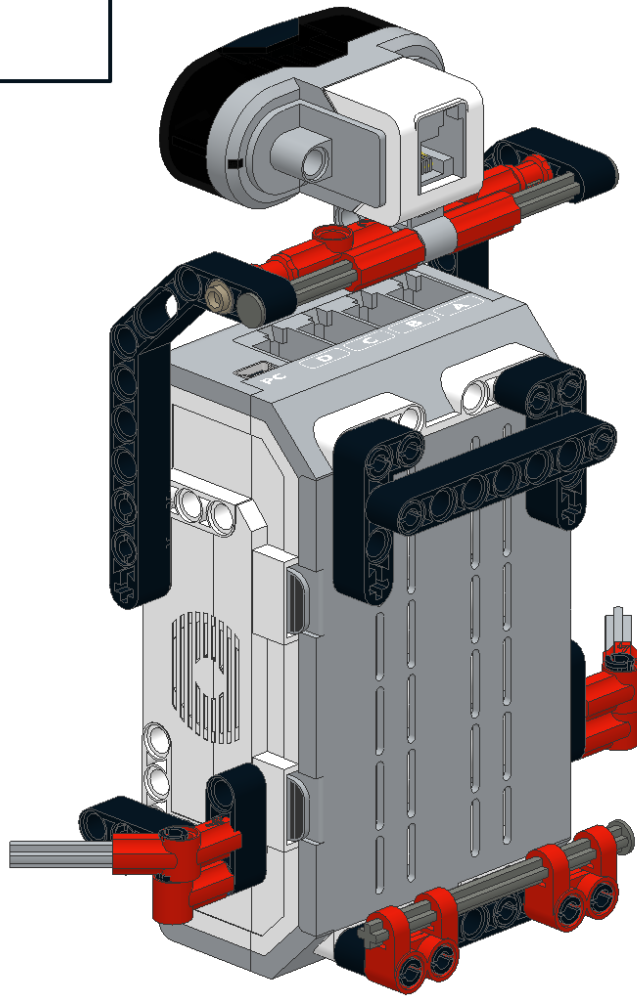
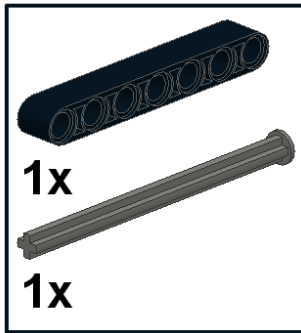

# Arms

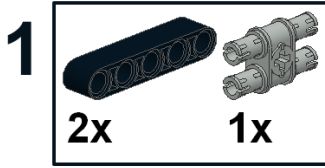

**2**

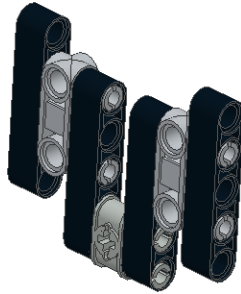
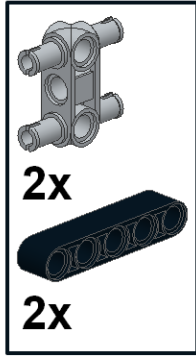

3   
4x



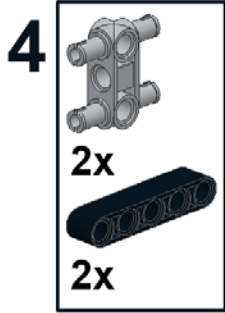



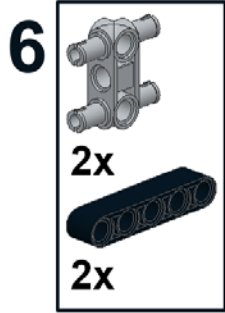

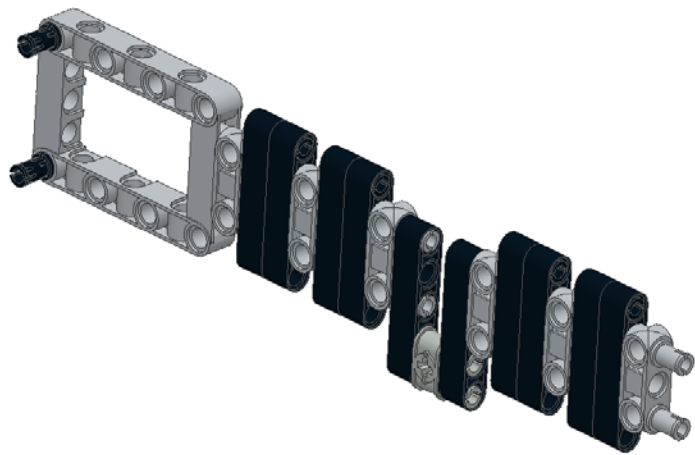
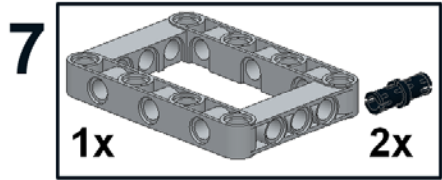

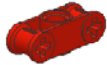

8   
2x

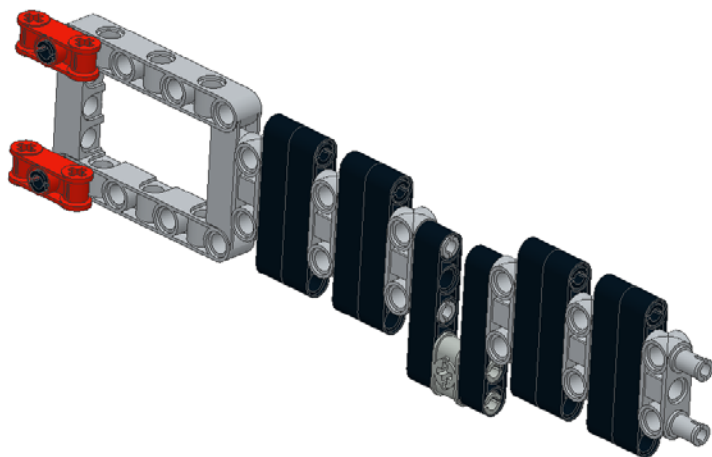

9

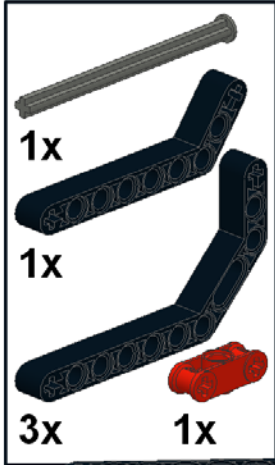

10

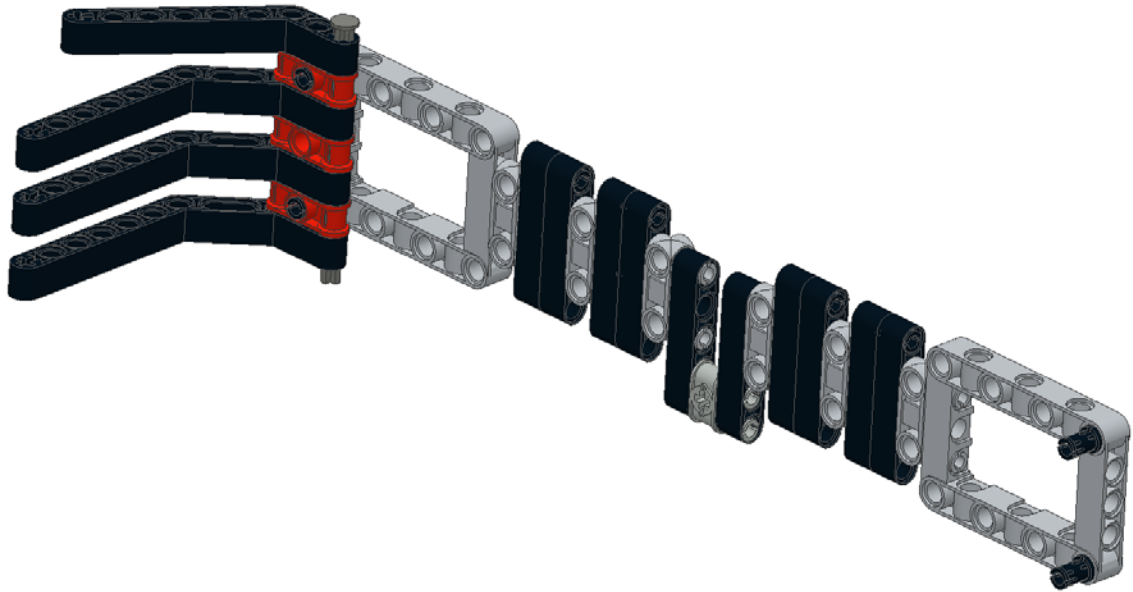
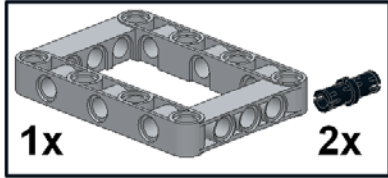

11   
2x

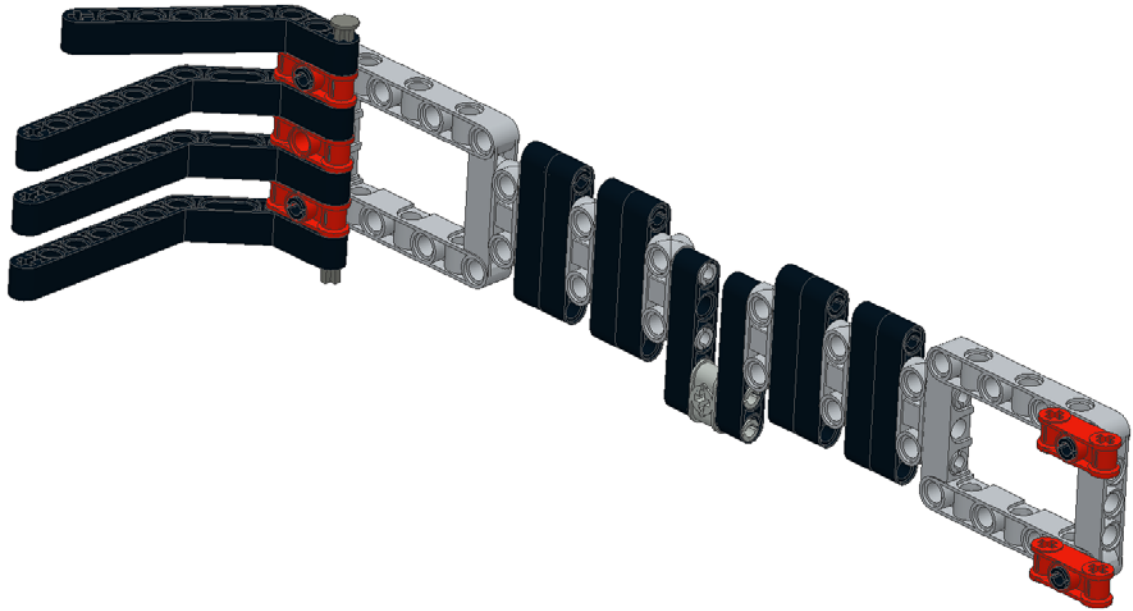

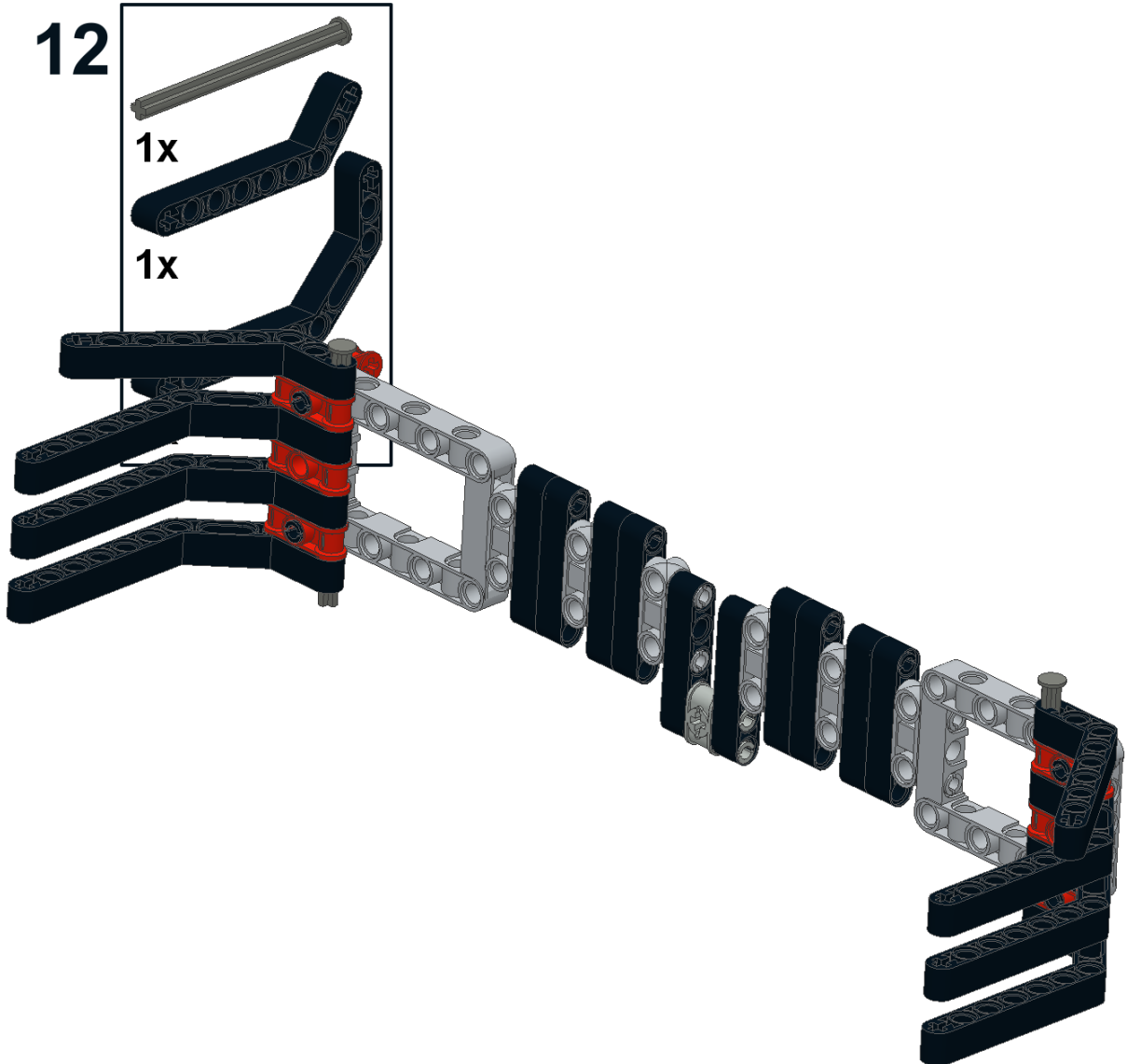

# Arm Control Motor

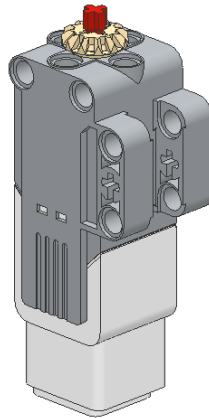
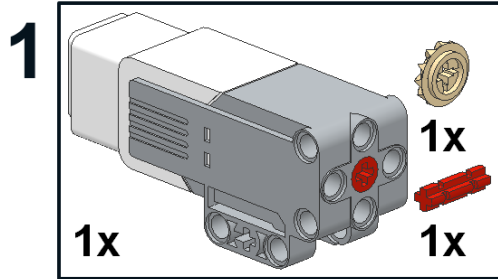

2   
4x

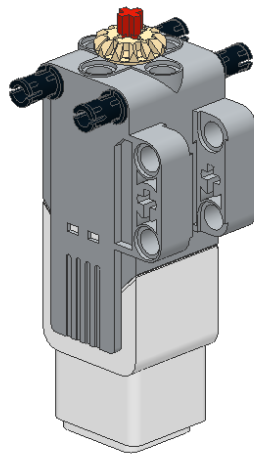

**3**

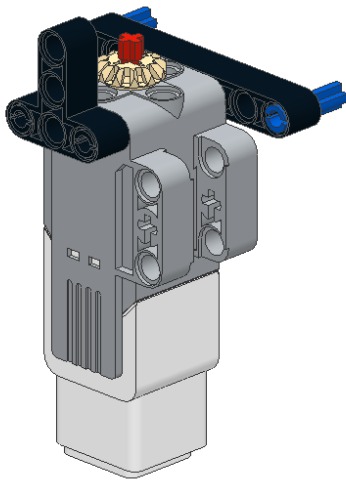
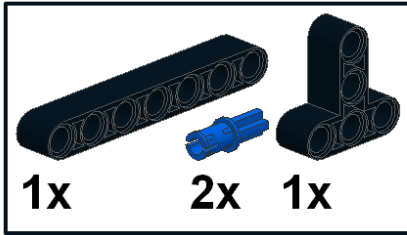



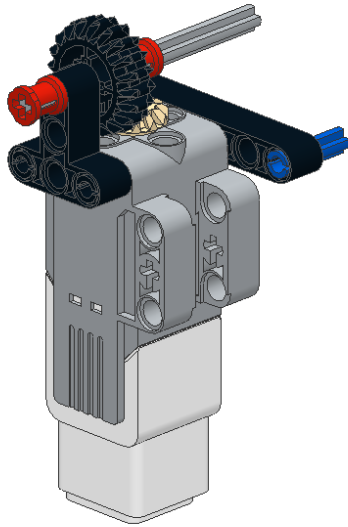
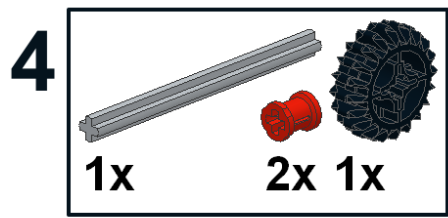

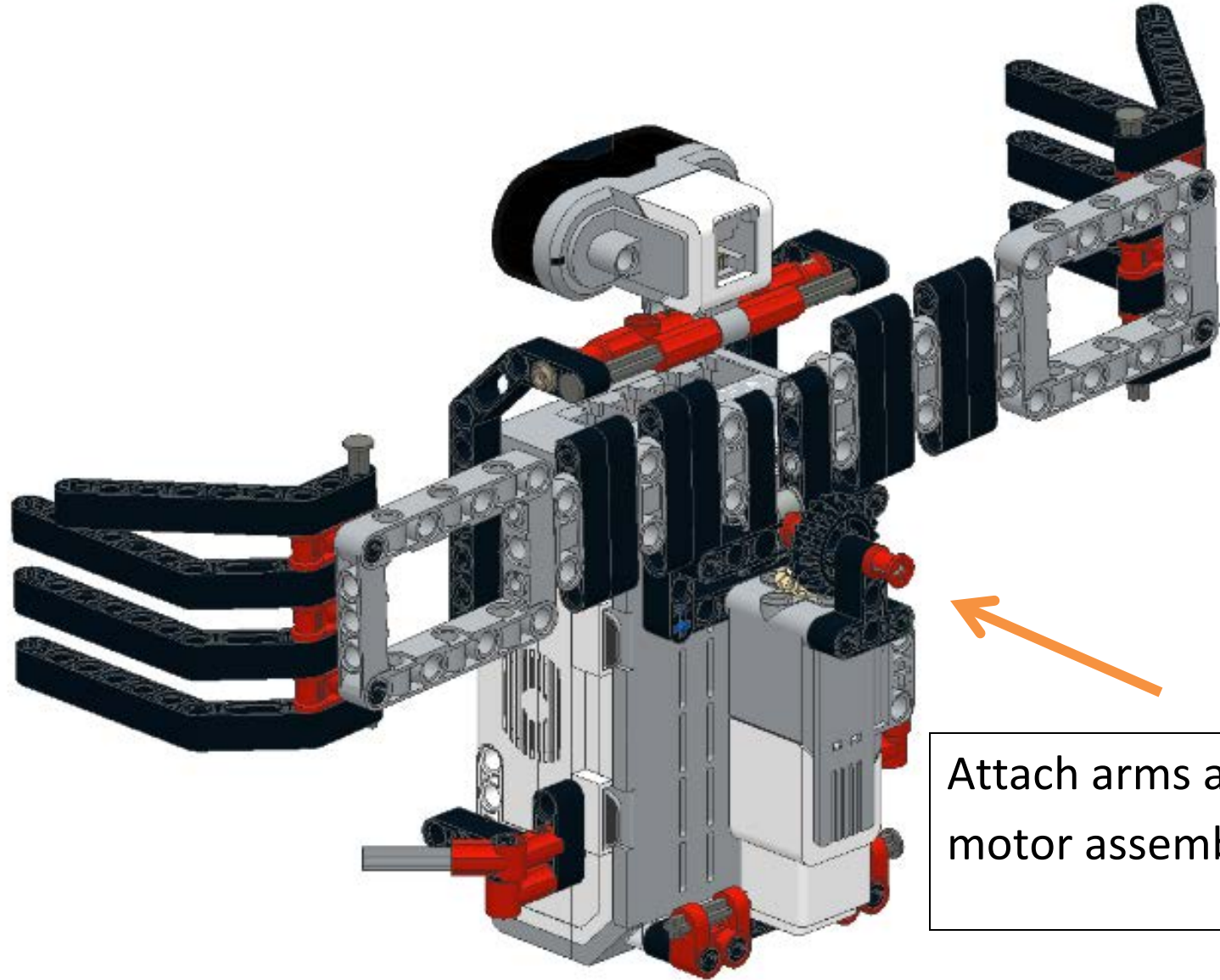

Attach arms and small motor assembly.

# Right Leg

1

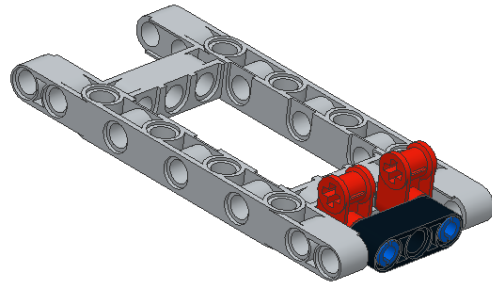
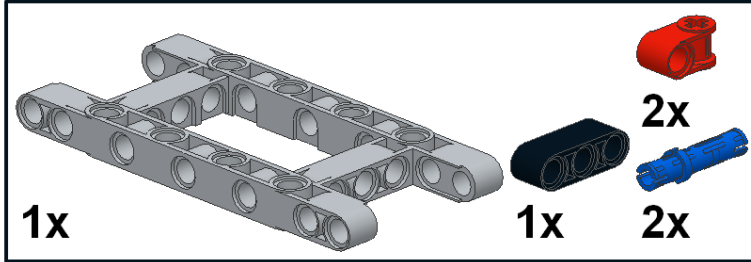

2

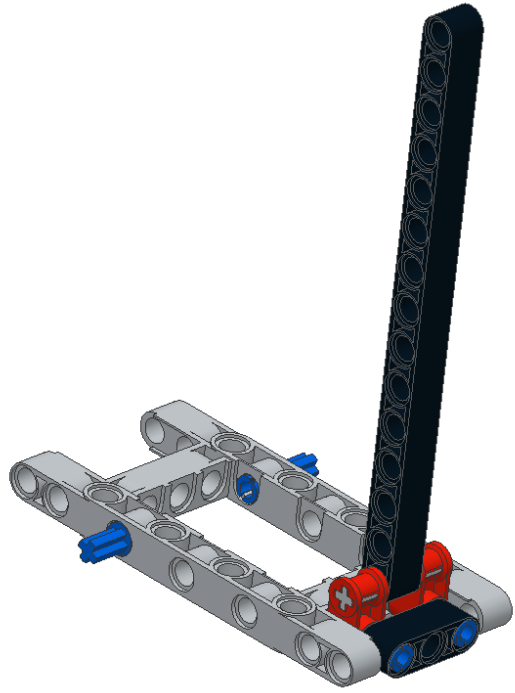
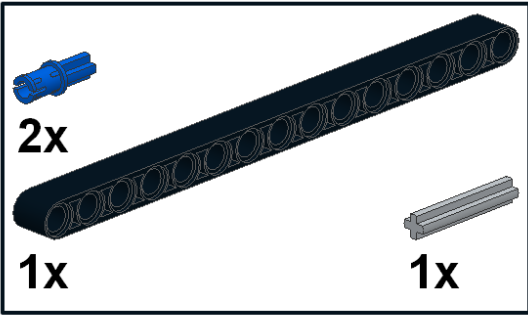

3

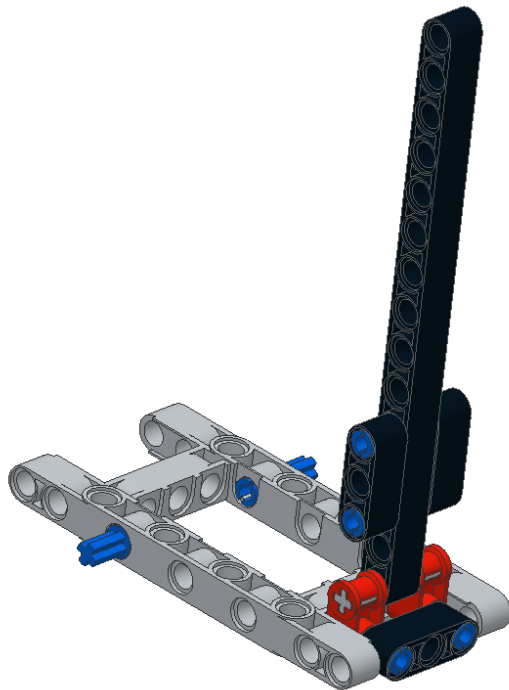
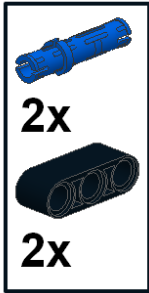

4

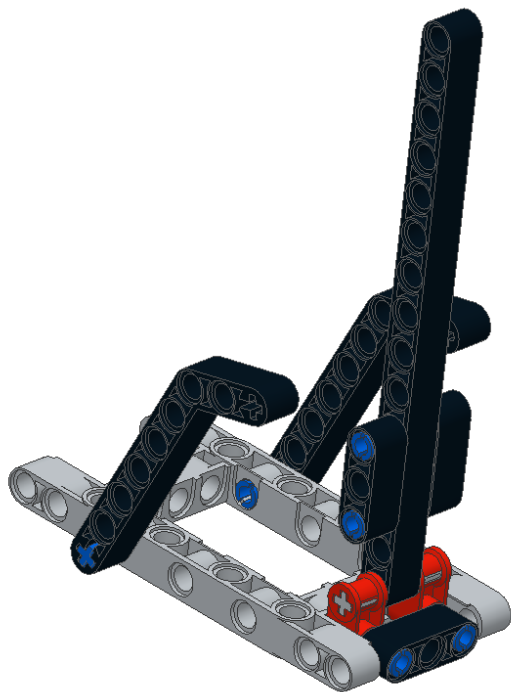
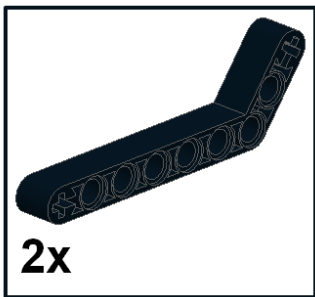

**5**



**1x**

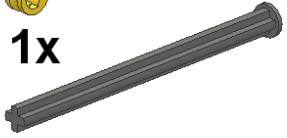

**1x**

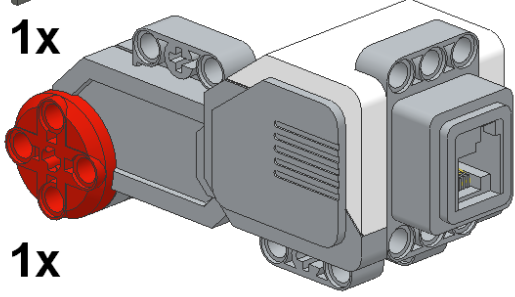

**1x**

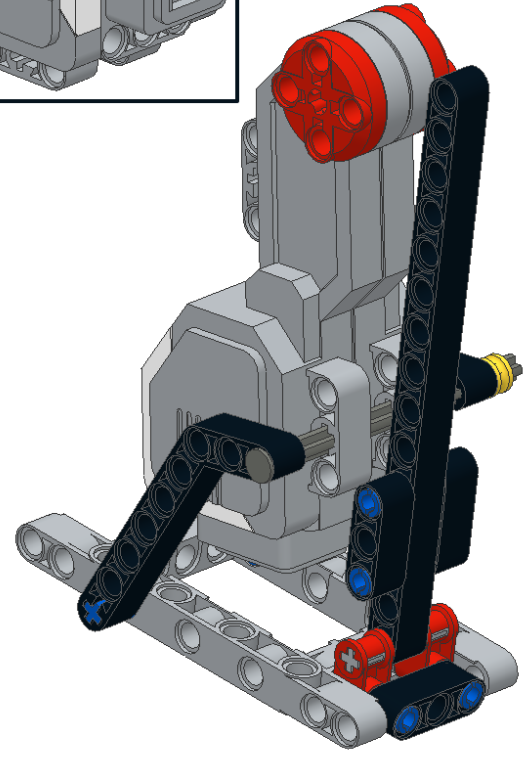

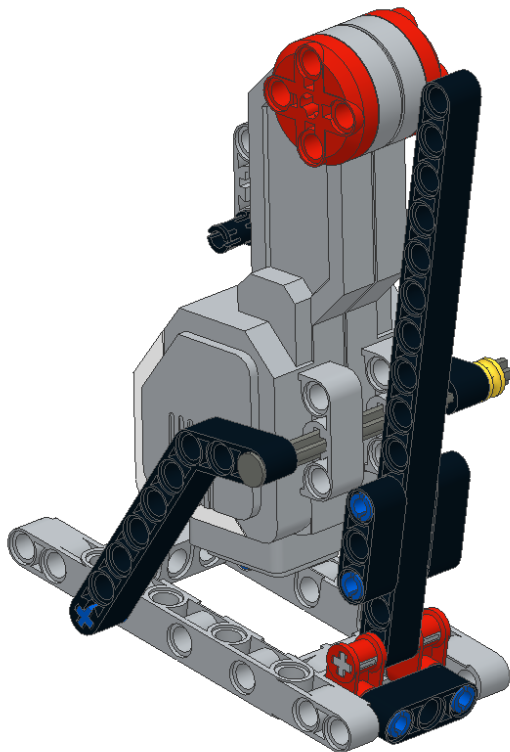

6   
1x



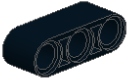

7

-   
1x
-   
1x
-   
1x

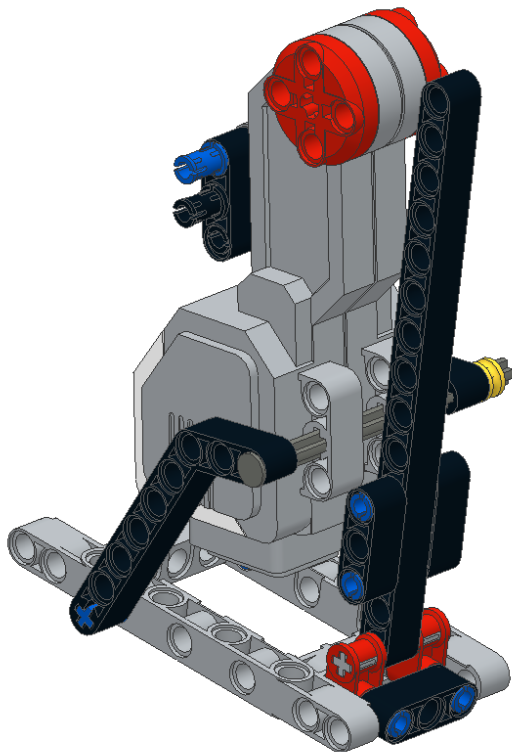

8

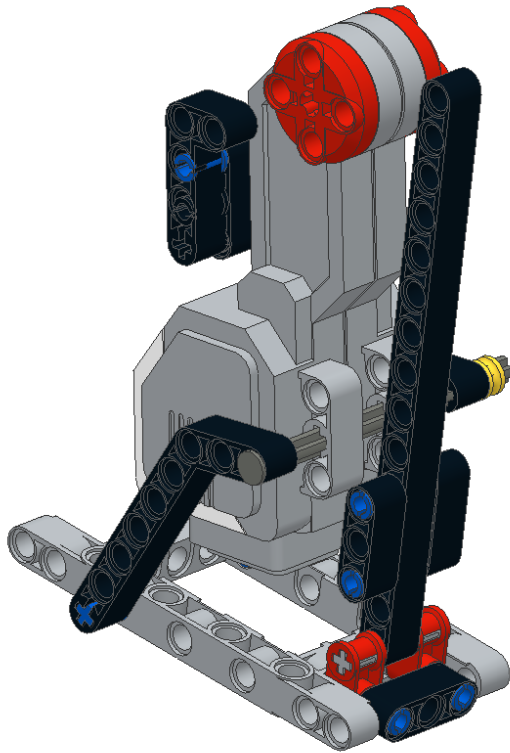
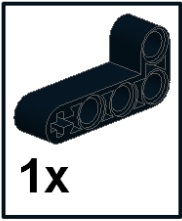

9   
2x

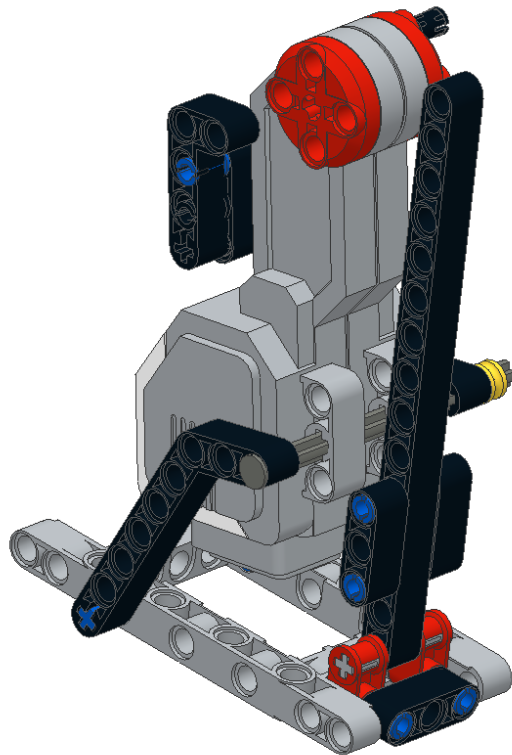

10

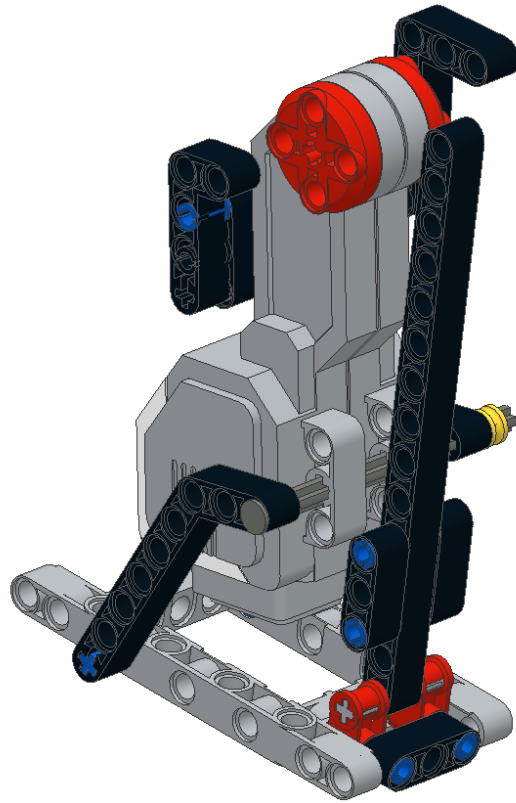
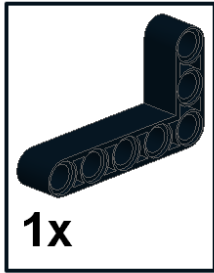

11

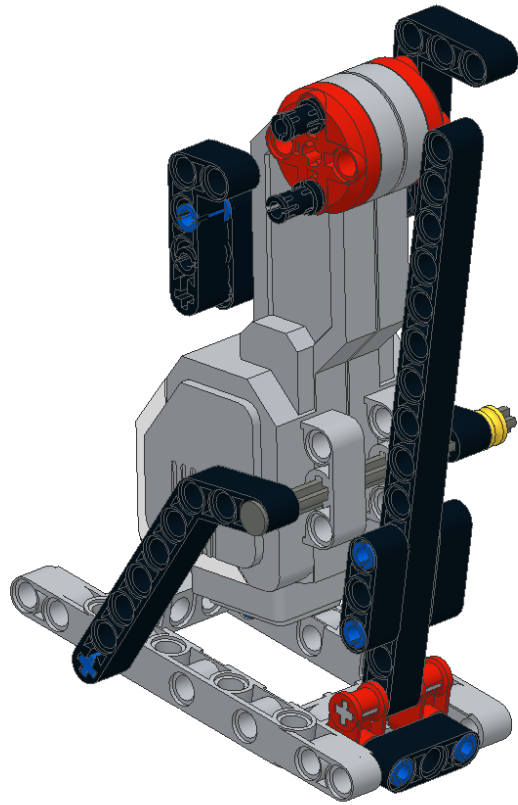

12   
1x

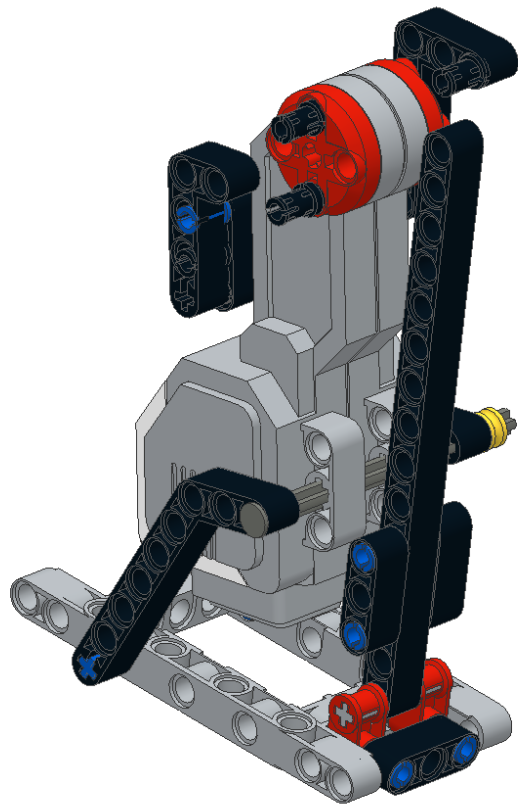

13

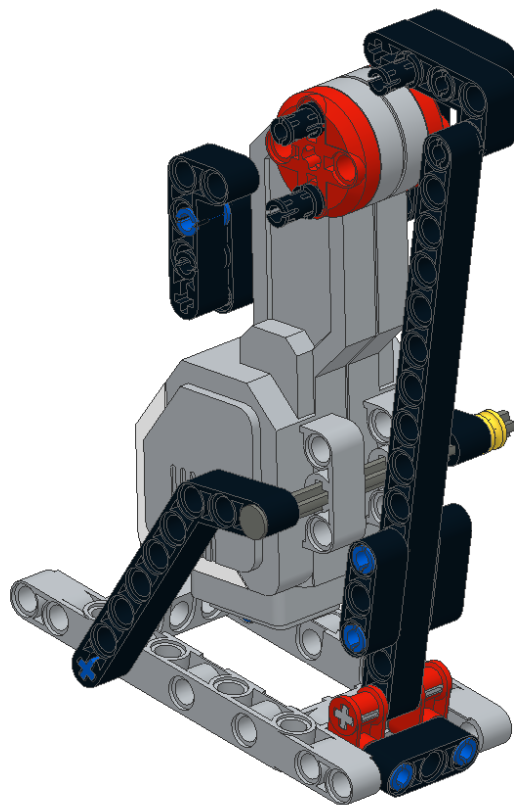
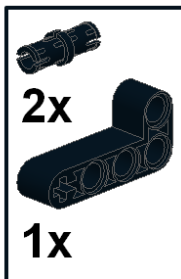

14

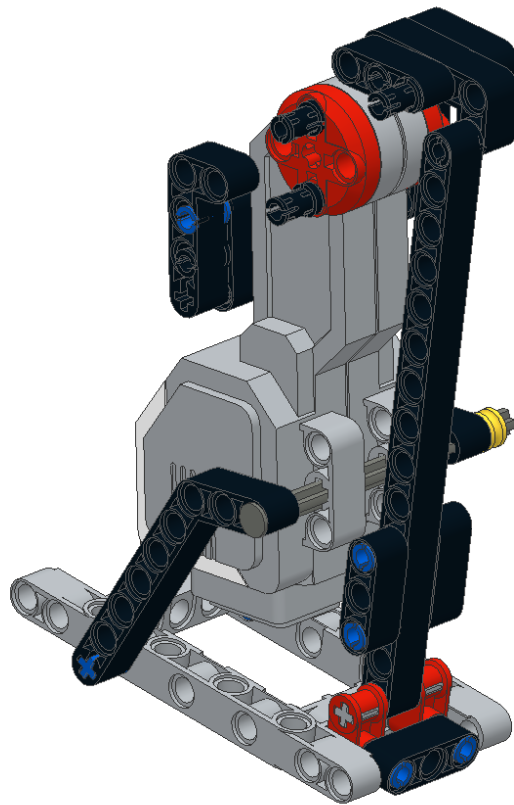
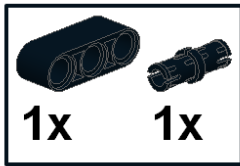



15

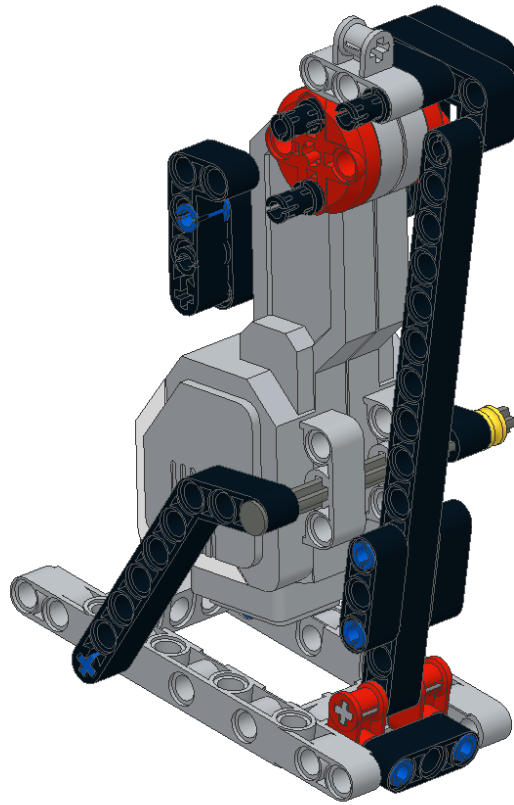
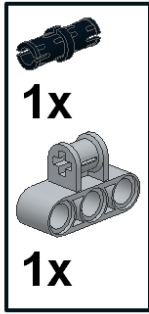

16

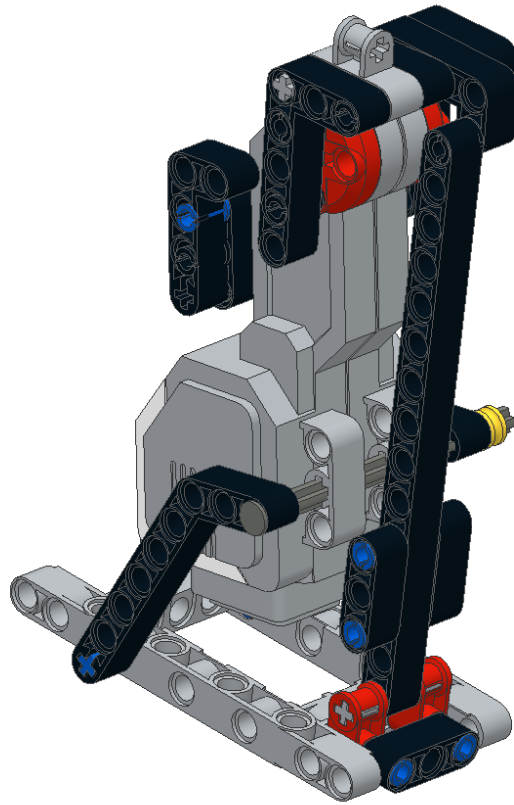
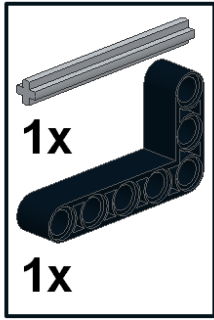

# Left Leg

1

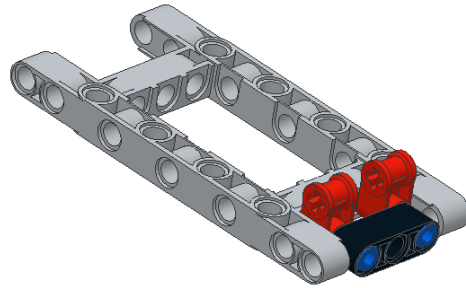
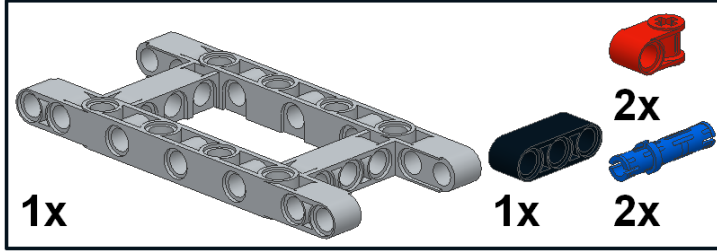

2   
4x

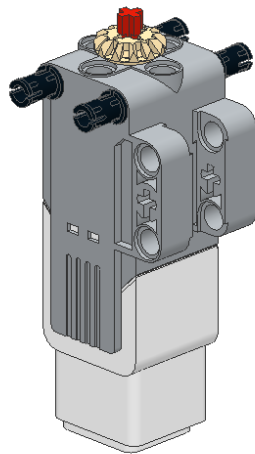

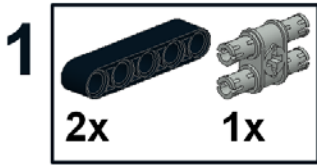

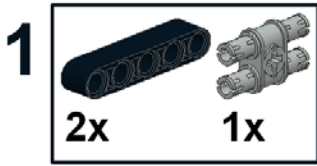

2

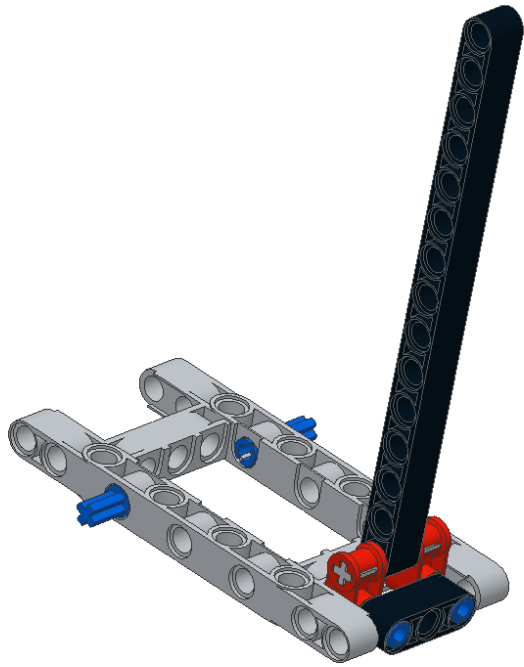
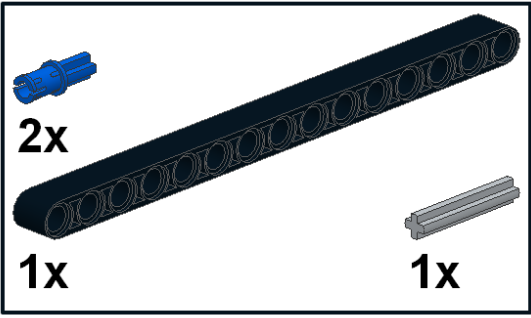

3

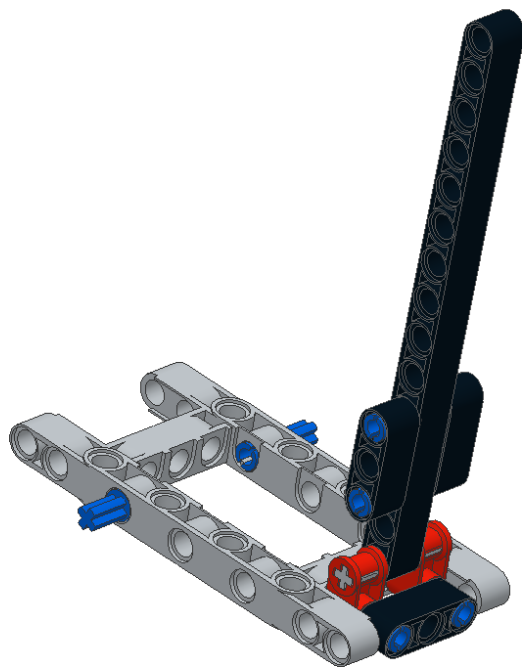
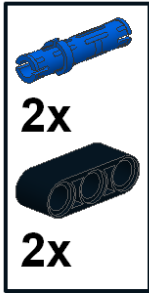



4

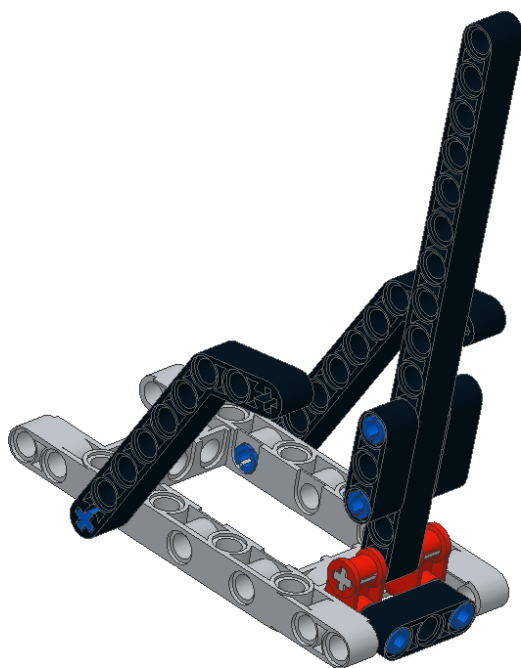

**5**



**1x**

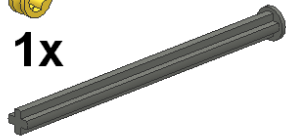

**1x**

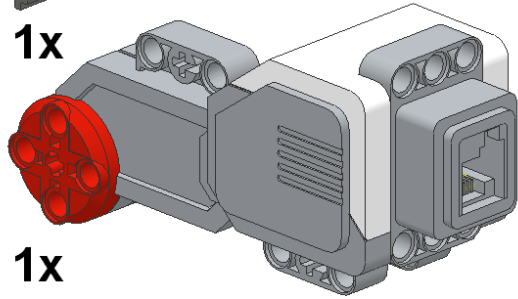

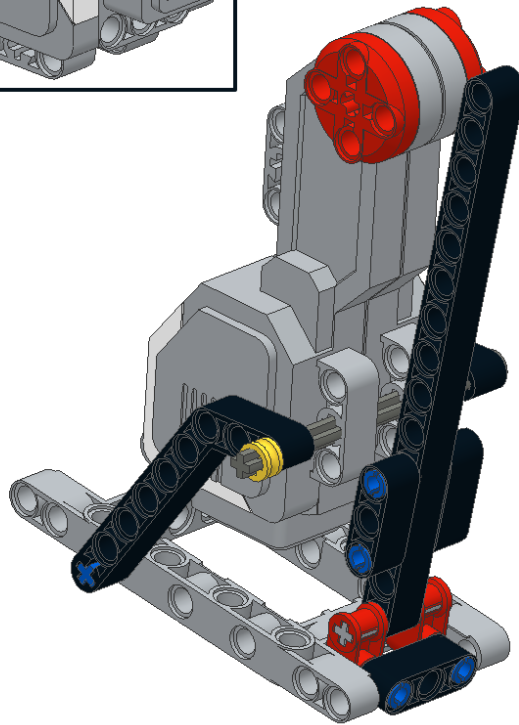

**1x**

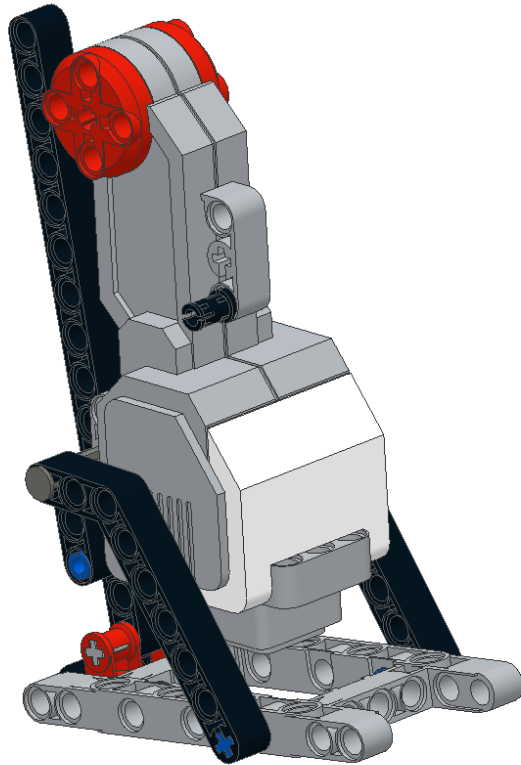

6   
1x

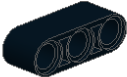

7

-  1x
-  1x
-  1x

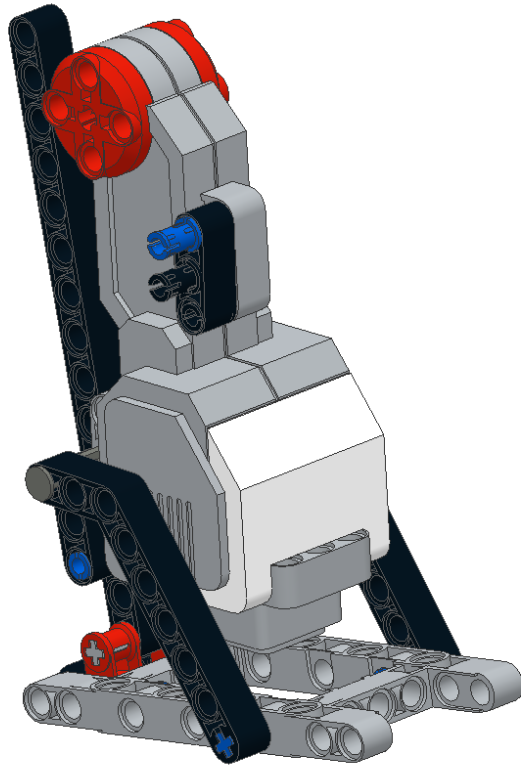

8

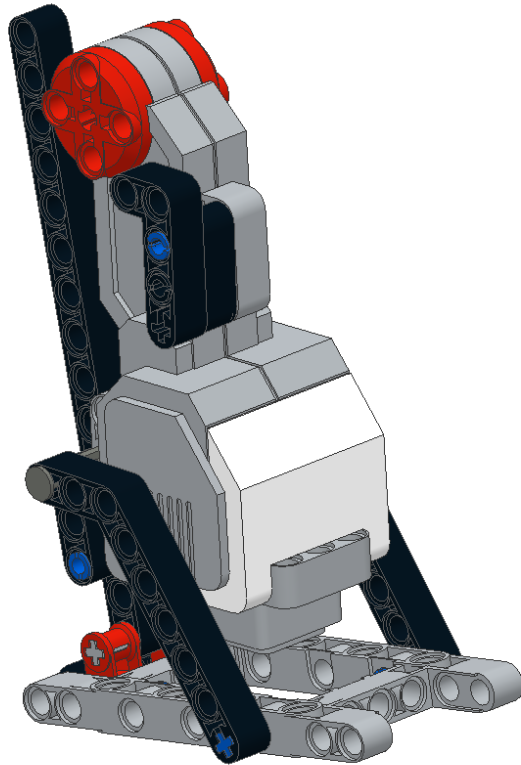
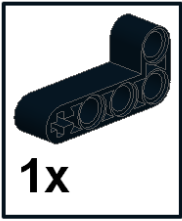

9   
2x

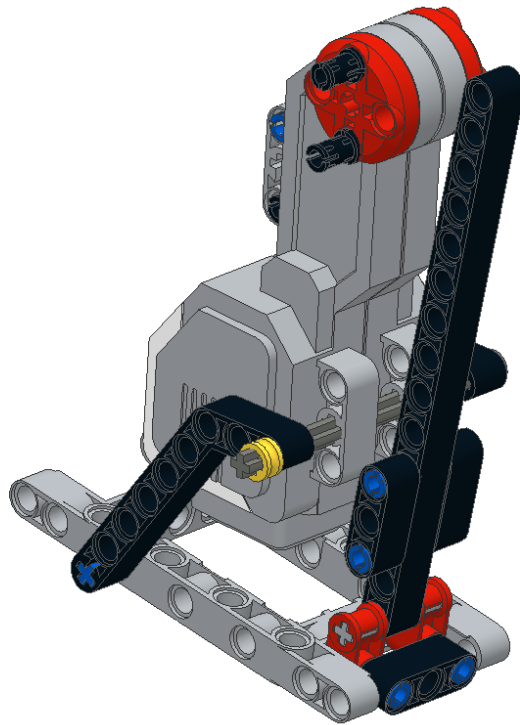

10

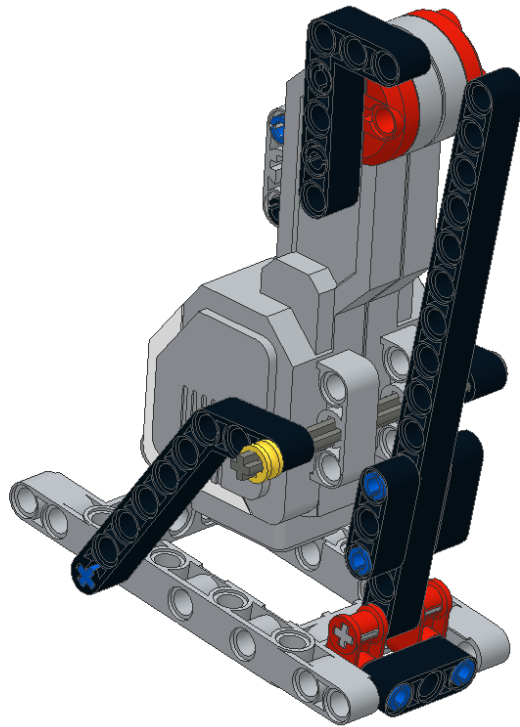
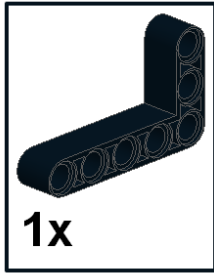

11

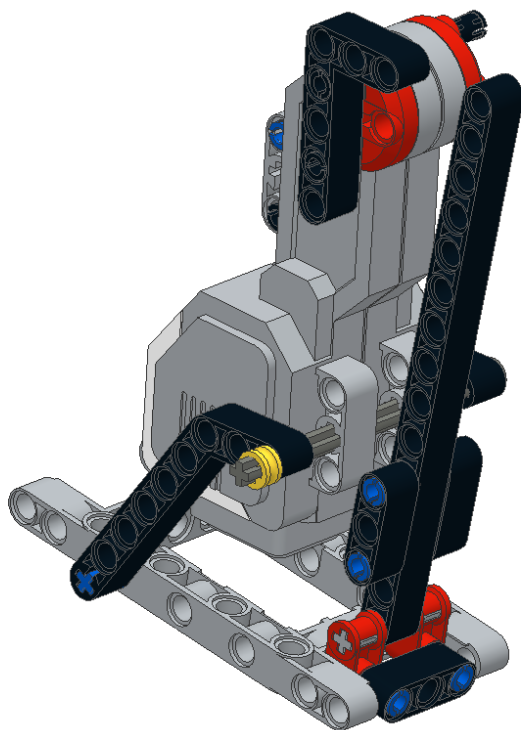



12   
1x

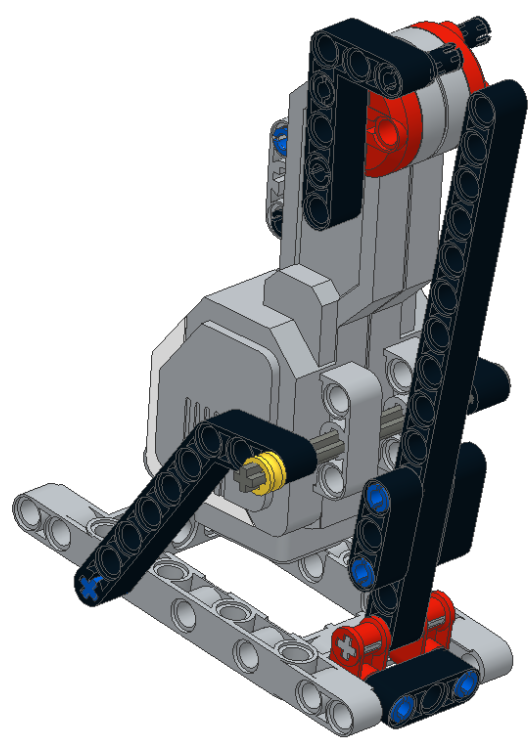

13

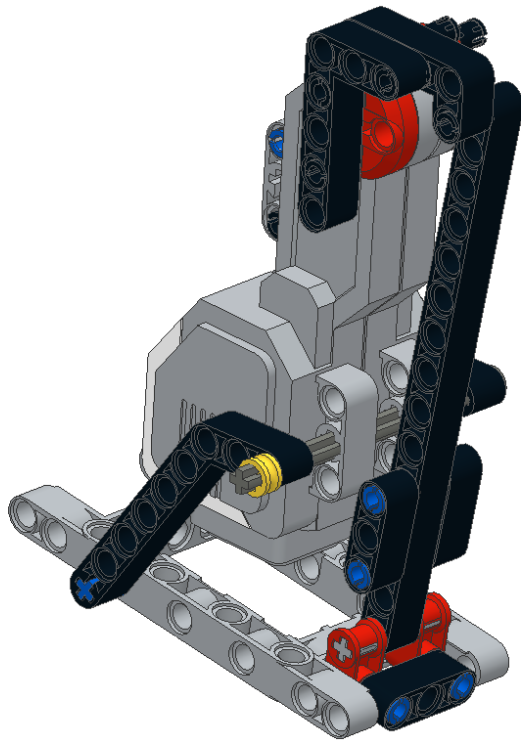
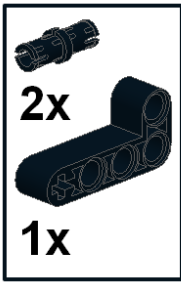

14

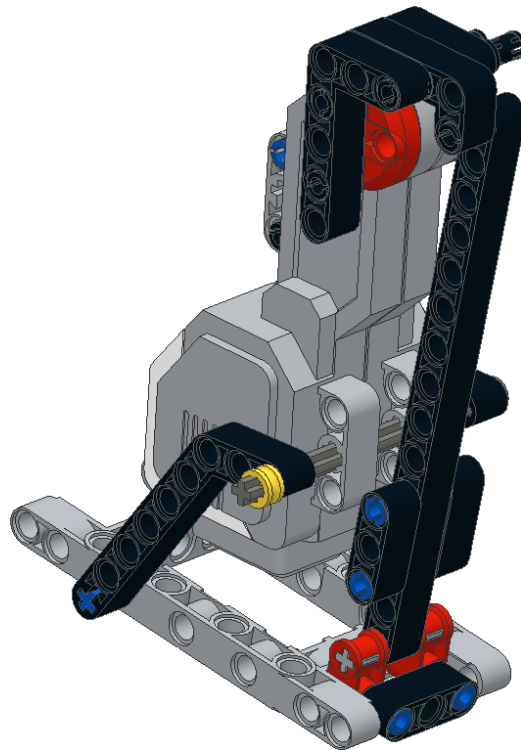
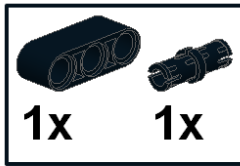



16

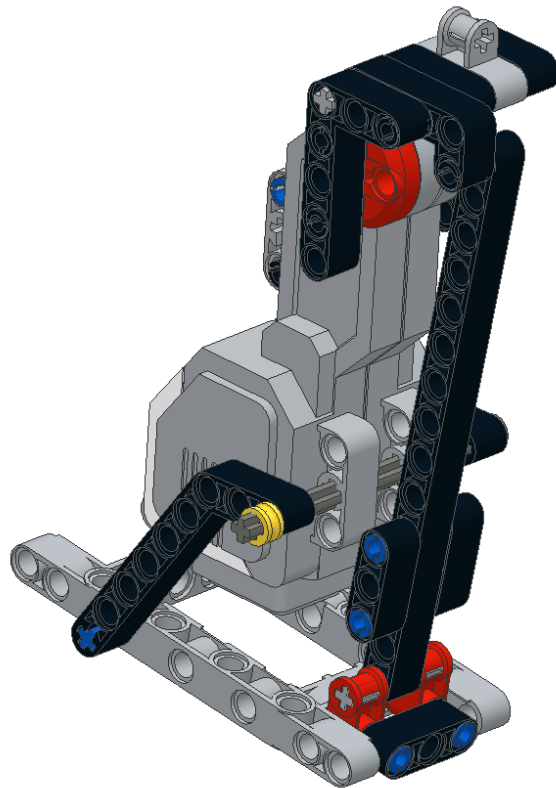
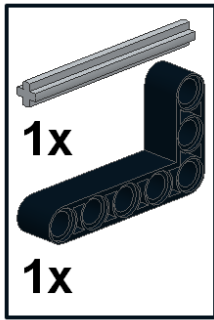

Slide legs into position and secure with red cross axle couplings.

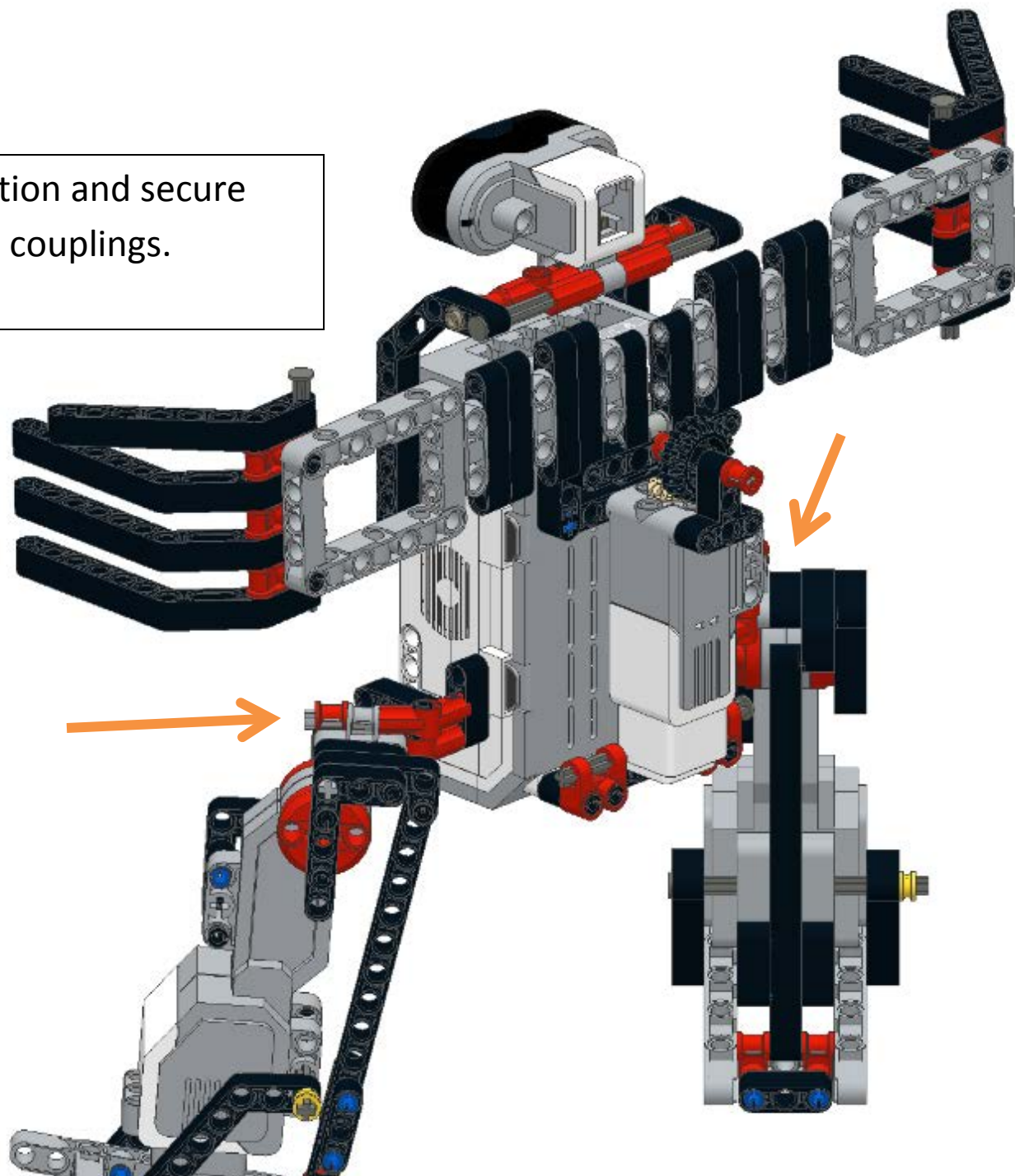

## **Connect Wires:**

**25cm Wire from EV3 Infrared Sensor --> EV3 Brick Port 2**

**35cm Wire from Medium Motor → EV3 Brick Port A (Route behind medium motor)**

**50cm Wire from Left Leg large motor → EV3 Brick Port C**

**50cm Wire from Right Leg large motor → EV3 Brick Port B**

**(Route 50cm Wires behind 8cm leg pins and behind medium motor)**

# Parts List

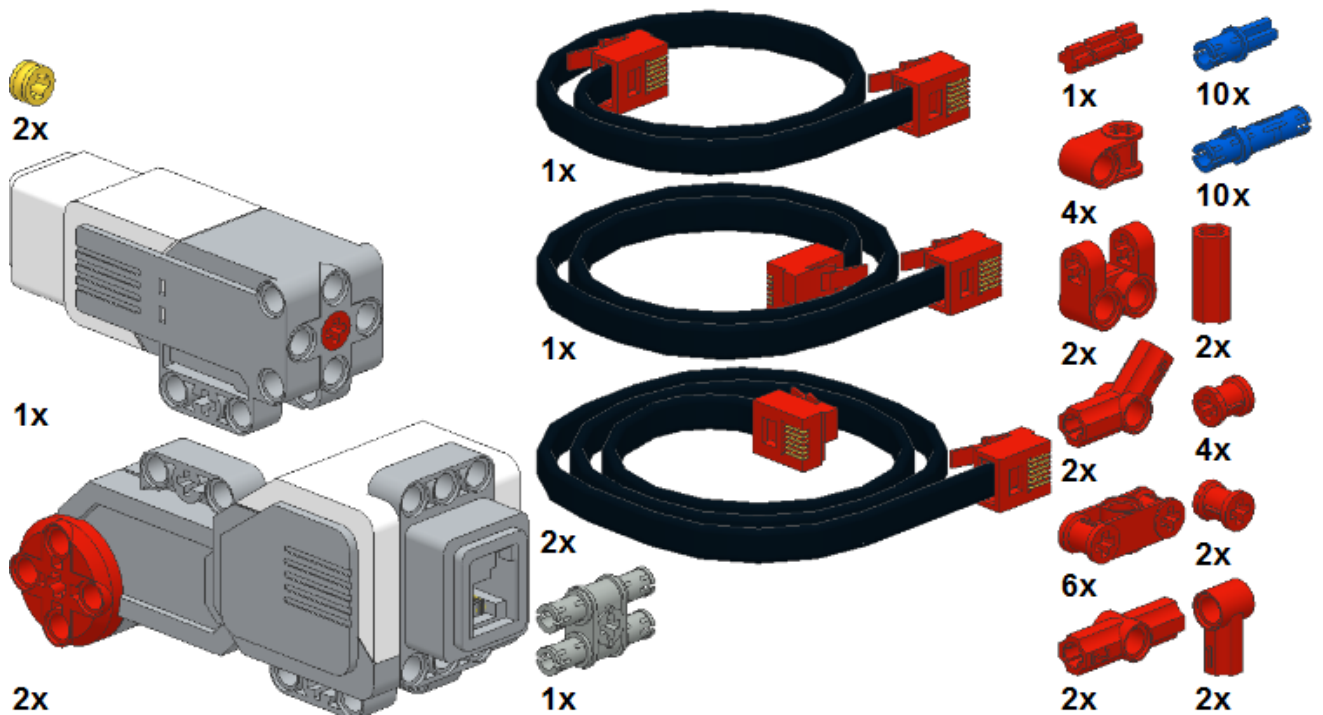
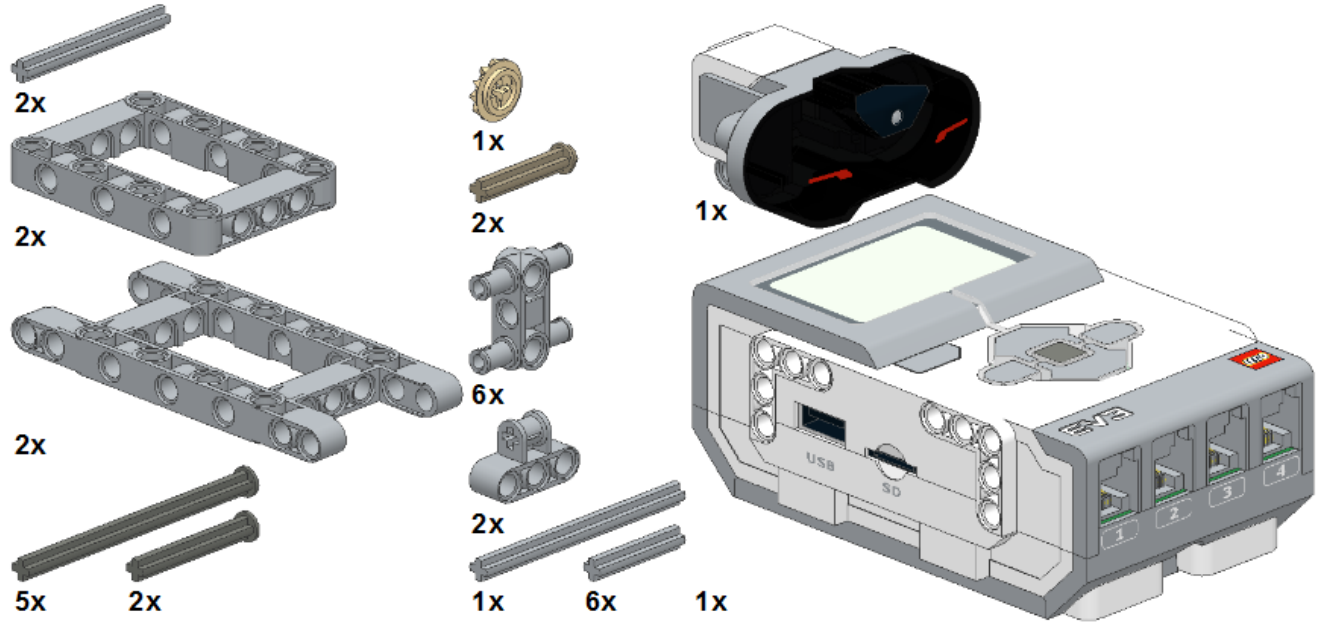





10x

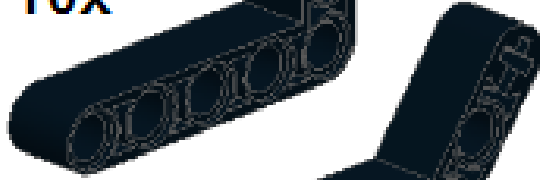

6x

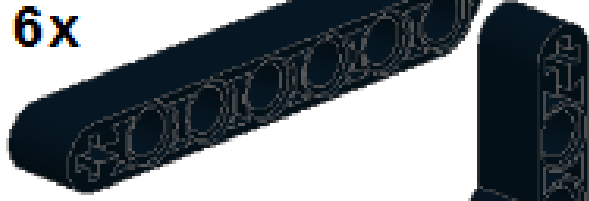

6x

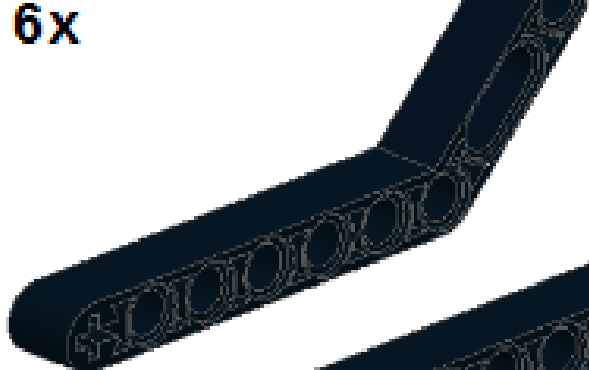

8x



2x

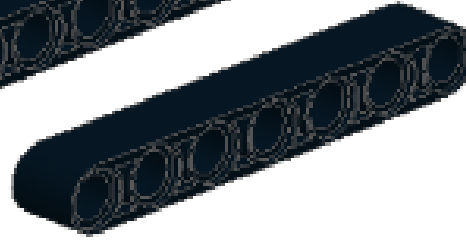

3x



62x

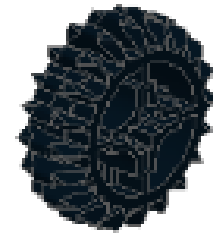

1x

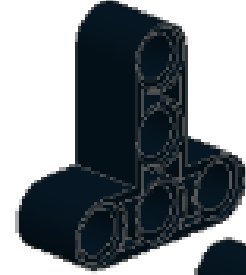

1x



6x

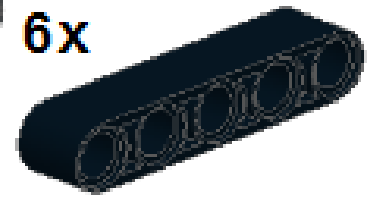

10x